

VEHICROSS

RESTRAINTS

SRS CONTROL SYSTEM

CONTENTS

Service Precaution	9J1-1	DTC 19 Passenger Deployment Loop Short To Voltage	9J1-25
Diagnostic Information	9J1-2	DTC 21 Driver Deployment Loop Resistance High	9J1-27
Parts For Electrical Circuit	9J1-4	DTC 22 Driver Deployment Loop Resistance Low	9J1-30
System Schematic	9J1-5	DTC 24 Driver Deployment Loop Short To Ground	9J1-33
SRS Diagnostic System Check	9J1-5	DTC 25 Driver Deployment Loop Short To Voltage	9J1-35
Chart A SDM Integrity Check	9J1-8	DTC 26 Driver Deployment Loop Open	9J1-38
Chart B "AIR BAG" Warning Lamp Comes "ON" Steady	9J1-10	DTC 51 Deployment Event Commanded ...	9J1-41
Chart C "AIR BAG" Warning Lamp Does Not Come "ON" Steady	9J1-12	DTC 53 Deployment Commanded With Deployment Loop Fault Or Energy Reserves Out Of Range	9J1-43
DTC 15 Passenger Deployment Loop Resistance High	9J1-15	DTC 61 Warning Lamp Circuit Failure	9J1-45
DTC 16 Passenger Deployment Loop Resistance Low	9J1-18	DTC 71 Internal SDM Fault	9J1-47
DTC 17 Passenger Deployment Loop Open	9J1-21		
DTC 18 Passenger Deployment Loop Short To Ground	9J1-23		

Service Precaution

WARNING: THIS VEHICLE HAS A SUPPLEMENTAL RESTRAINT SYSTEM (SRS). REFER TO THE SRS COMPONENT AND WIRING LOCATION VIEW IN ORDER TO DETERMINE WHETHER YOU ARE PERFORMING SERVICE ON OR NEAR THE SRS COMPONENTS OR THE SRS WIRING. WHEN YOU ARE PERFORMING SERVICE ON OR NEAR THE SRS COMPONENTS OR THE SRS WIRING, REFER TO THE SRS SERVICE INFORMATION. FAILURE TO FOLLOW WARNINGS COULD RESULT IN POSSIBLE AIR BAG DEPLOYMENT, PERSONAL INJURY, OR OTHERWISE UNNEEDED SRS SYSTEM REPAIRS.

CAUTION: Always use the correct fastener in the proper location. When you replace a fastener, use ONLY the exact part number for that application. ISUZU will call out those fasteners that require a replacement after removal. ISUZU will also call out the fasteners that require thread lockers or thread sealant. UNLESS OTHERWISE SPECIFIED, do not use supplemental coatings (Paints, greases, or other corrosion inhibitors) on threaded fasteners or fastener joint interfaces. Generally, such coatings adversely affect the fastener torque and the joint clamping force, and may damage the fastener. When you install fasteners, use the correct tightening sequence and specifications. Following these instructions can help you avoid damage to parts and systems.

Diagnostic Information

Diagnostic Procedures

WARNING: WHEN FASTENERS ARE REMOVED, ALWAYS REINSTALL THEM AT THE SAME LOCATION FROM WHICH THEY WERE REMOVED. IF A FASTENER NEEDS TO BE REPLACED, USE THE CORRECT PART NUMBER FASTENER FOR THAT APPLICATION. IF THE CORRECT PART NUMBER FASTENER IS NOT AVAILABLE, A FASTENER OF EQUAL SIZE AND STRENGTH (OR STRONGER) MAY BE USED. FASTENERS THAT ARE NOT REUSED, AND THOSE REQUIRING THREAD LOCKING COMPOUND WILL BE CALLED OUT. THE CORRECT TORQUE VALUE MUST BE USED WHEN INSTALLING FASTENERS THAT REQUIRE IT. IF THE ABOVE CONDITIONS ARE NOT FOLLOWED, PARTS OR SYSTEM DAMAGE COULD RESULT.

WARNING: TO AVOID DEPLOYMENT WHEN TROUBLESHOOTING THE SRS, DO NOT USE ELECTRICAL TEST EQUIPMENT SUCH AS A BATTERY-POWERED OR AC-POWERED VOLTMETER, OHMMETER, ETC., OR ANY TYPE OF ELECTRICAL EQUIPMENT OTHER THAN THAT SPECIFIED IN THIS MANUAL. DO NOT USE A NONPOWERED, PROBE-TYPE TESTER. INSTRUCTIONS IN THIS MANUAL MUST BE FOLLOWED CAREFULLY, OTHERWISE PERSONAL INJURY MAY RESULT.

The diagnostic procedures used in this section are designed to aid in finding and repairing SRS problems. Outlined below are the steps to find and repair SRS problems quickly and effectively. Failure to carefully follow these procedures may result in extended diagnostic time, incorrect diagnosis and incorrect parts Replacement.

1. Perform The “SRS Diagnostic System Check.”

The “Supplemental Restraint System (SRS) Diagnostic System Check” should always be the starting point of any SRS diagnostics. The “SRS Diagnostic System Check” checks for proper “AIR BAG” warning lamp operation and checks for SRS trouble codes using both “Flash Code” and “Scan Tool” Methods.

2. Refer To The Proper Diagnostic Chart As Directed By The “SRS Diagnostic System Check.”

The “SRS Diagnostic System Check” will lead you to the correct chart to diagnose any SRS problems. Bypassing these procedures may result in extended diagnostic time, incorrect diagnosis and incorrect parts Replacement.

3. Repeat the “SRS Diagnostic System Check” After Any Repair Or Diagnostic Procedures Have Been Performed.

Performing the “SRS Diagnostic System Check” after all repair or diagnostic procedures will assure that the repair has been made correctly and that no other conditions exist.

Diagnostic Codes

The Sensing and Diagnostic Module (SDM) maintains a history record of all diagnostic codes that have been detected since the SRS codes were last cleared during service.

1. Active Codes—Faults that are presently detected this ignition cycle. Active codes are stored in Random Access Memory (RAM).
2. History Codes—All faults detected since the last time the history fault memory was cleared. History codes are stored in Electronically Erasable Programmable Read only Memory (EEPROM).

How To Read Trouble Codes

All codes (Active and history) can be read (or cleared) by using a scan tool or equivalent.

If a Diagnostic Trouble Code (DTC) is not available, have the vehicle serviced by dealer.

How To Clear Trouble Codes

Trouble codes can only be cleared by using a scan tool. If a scan tool is not available then inform the owner of the stored codes and suggest that the codes are cleared upon the next visit to a dealership.

Scan Tool Diagnostics

A scan tool can be used to read current and history codes and to clear all history codes after a repair is complete. The scan tool must be updated to communicate with the SRS through a replaceable cartridge for SRS diagnostics. To use the scan tool, connect it to the Data Link Connector (DLC) and turn the ignition switch “ON”. Then follow the manufacturer’s directions for communication with the SRS. The scan tool reads serial data from the Sensing and Diagnostic Module (SDM) “Serial Data” output (terminal 24) to the DLC.

Basic Knowledge Required

Before using this section of the Service Manual, there is some basic knowledge which will be required. Without this knowledge, you will have trouble using the diagnostic procedures in this section. Use care to prevent harm or unwanted deployment. Read all cautions in the service manual and on warning labels attached to SRS components.

Basic Electrical Circuits

You should understand the basic theory of electricity including series and parallel circuits, and understand the voltage drops across series resistors. You should know the meaning of voltage (volts), current (amps), and resistance (ohms). You should understand what happens in a circuit with an open or a shorted wire. You should be able to read and understand a wiring diagram.

“Flash Code” Diagnostics

Flash code diagnostics can be used to read current codes and to determine if history codes are present but cannot be used to clear codes or read history codes. Flash code diagnostics is enabled by grounding by terminal 13 shorting to terminal 4 of the DLC with the ignition switch “ON”. Grounding terminal 13 of the DLC pulls the “Diagnostics Request” input (Terminal 1) of the SDM low and signals the SDM to enter the flash code diagnostic display mode.

The SDM displays the trouble codes by flashing the warning lamp. Each code that is displayed will consist of a number of flashes which represents the tens digit, a 1.2 second pause, following by a number of flashes which represents the ones digit of the code. Each code is displayed one time before moving on to the next code. After all of the codes have been displayed, the entire code sequence will continually be repeated until ground is removed from terminal 13 of the DLC.

Two special codes exist when reading in the flash code mode (Flash Code 12 and Flash Code 13). “Flash Code 12” will always be the first code displayed when the flash code mode is enabled. Code 12 is not an indication of a SRS problem but an indication that the flash code mode has been enabled. If there are no current or history codes present, the SDM will display code 12 until ground is removed from the DLC at terminal 13. “Flash Code 13” will be displayed if there are history codes. To read the history codes, a scan tool must be used.

Parts For Electrical Circuit

Wiring

Wire Color

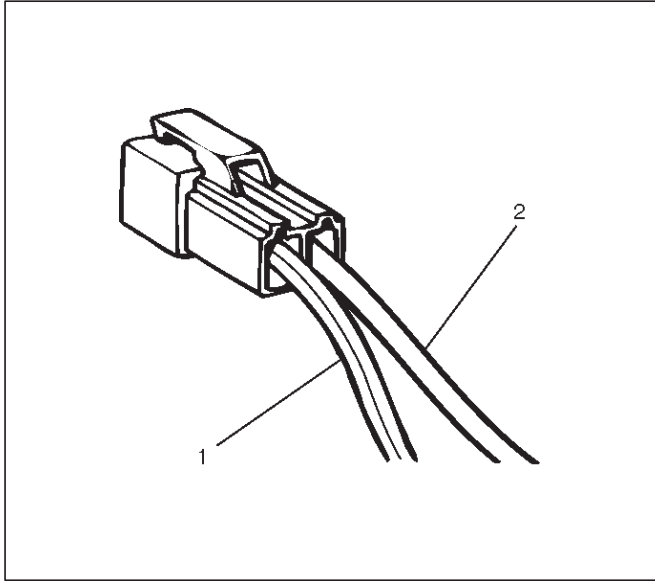

D08RX174

Legend

- (1) Colored Stripe
- (2) Single Color

All wires have color-coded insulation. Wires belonging to a system's main harness will have a single color. Wires belonging to a system's sub-circuits will have a colored stripe. Striped wires use the following code to show wire size and colors.

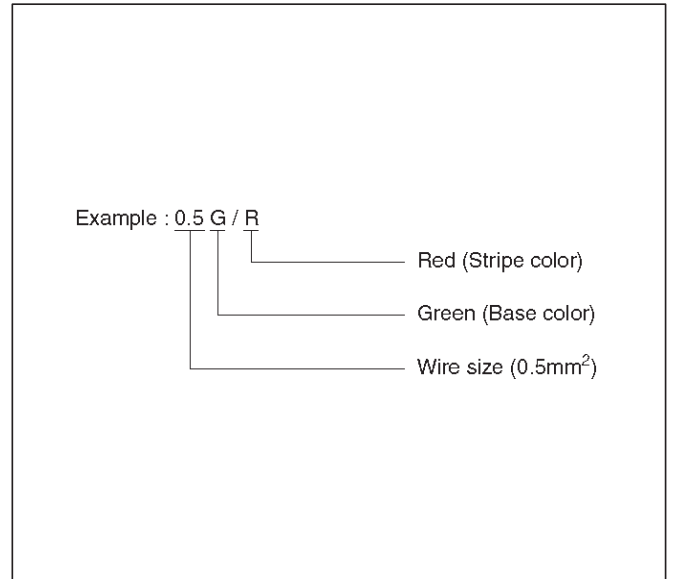

D08RX175

Abbreviations are used to indicate wire color within a circuit diagram. Refer to the following table.

Wire Color Coding

Color-coding	Meaning	Color-coding	Meaning
B	Black	BR	Brown
W	White	LG	Light green
R	Red	GR	Grey
G	Green	P	Pink
Y	Yellow	LB	Light blue
L	Blue	V	Violet
O	Orange		

Distinction of Circuit by Wire Base Color

Base color	Circuits	Base color	Circuits
B	Starter circuit and grounding circuit	Y	Instrument circuit
W	Charging circuit	L, O, BR, LG, GR, P, SB, V	Other circuit
R	Lighting circuit		
G	Signal circuits		

System Schematic

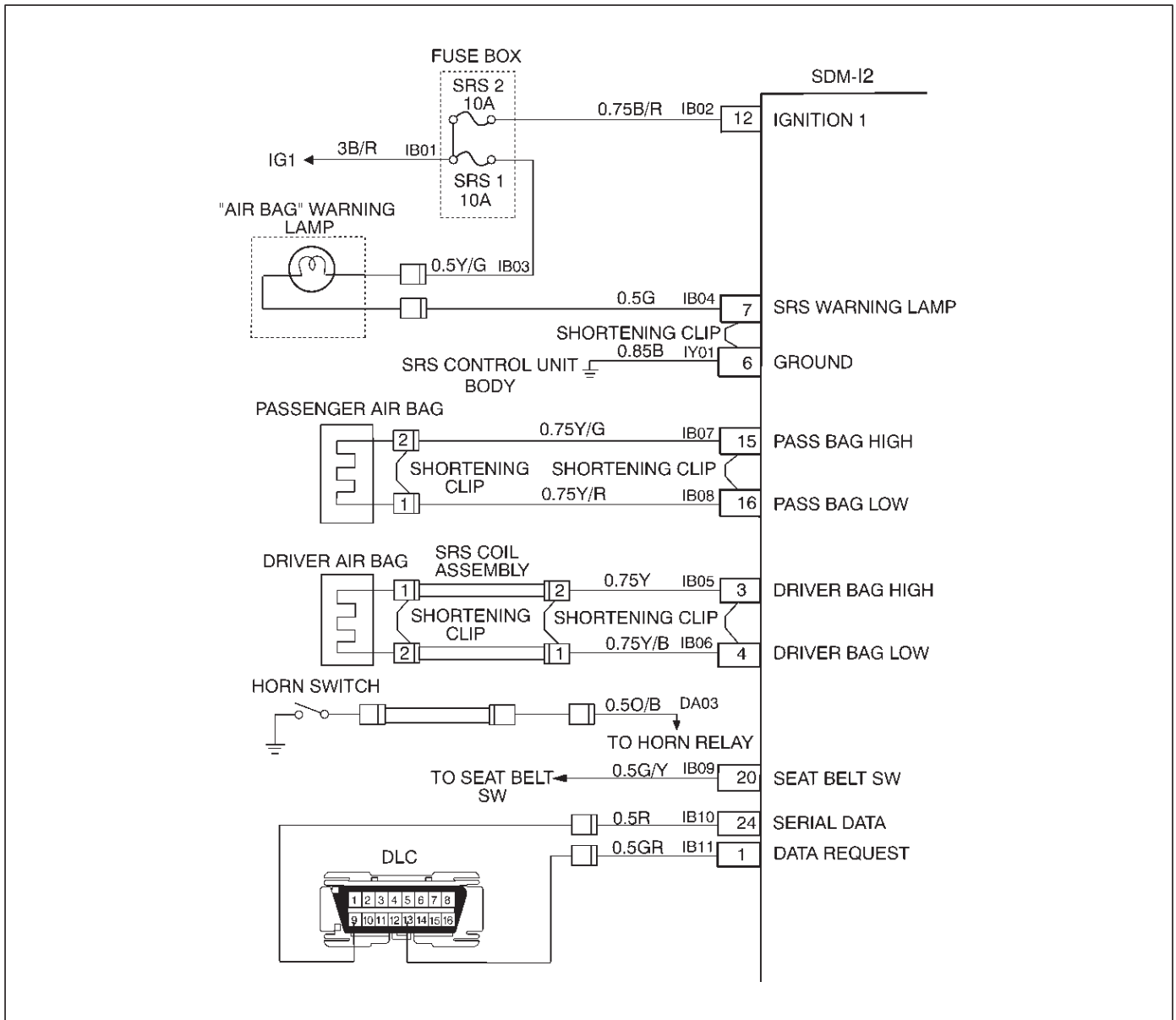

D09RX001

SRS Diagnostic System Check

The diagnostic procedures used in this section are designed to find and repair Supplemental Restraint System (SRS) malfunctions. To get the best results, it is important to use the diagnostic charts and follow the sequence listed below:

- Perform the "SRS Diagnostic System Check."

The "SRS Diagnostic System Check" must be the starting point of any SRS diagnostics. The "SRS Diagnostic System Check" checks for proper "AIR BAG" warning lamp operation, the ability of the Sensing and Diagnostic Module (SDM) to communicate through the "Serial Data" line and whether SRS diagnostic trouble codes exist.
- Refer to the proper diagnostic chart as directed by the "SRS Diagnostic System Check."

The "SRS Diagnostic System Check" will lead you to the correct chart to diagnose any SRS malfunctions. Bypassing these procedures may result in extended

diagnostic time, incorrect diagnosis and incorrect parts replacement.

- Repeat the "SRS Diagnostic System Check" after any repair or diagnostic procedures have been performed.

Performing the "SRS Diagnostic System Check" after all repair or diagnostic procedures will ensure that the repair has been made correctly and that no other malfunctions exist

Circuit Description

When the ignition switch is first turned "ON", "ignition 1" voltage is applied from the "SRS-2" fuse to the SDM at the "ignition 1" input terminals "12". The SDM responds by flashing the "AIR BAG" warning lamp seven times while performing tests on the SRS.

Notes On System Check Chart:

Number(s) below refer to step number(s) on the "Supplemental Restraint System Diagnostic System Check" chart.

1. The "AIR BAG" warning lamp should flash seven times after ignition is first turned "ON."
2. After the "AIR BAG" warning lamp flashes seven times, it should turn "OFF."
3. Improper operation of the "AIR BAG" warning lamp is indicated. This test differentiates a warning lamp stays "ON" condition from a warning lamp does not come "ON" condition.
4. This test checks for the proper operation of the "Serial Data" line. This test will also determine whether history diagnostic trouble codes are stored and, if so, identify them.
5. This test checks for proper operation of the "Serial Data" line. This test will also identify the stored diagnostic trouble codes and whether they are current or history.

Diagnostic Aids:

The order in which diagnostic trouble codes are diagnosed is very important. Failure to diagnose the diagnostic trouble codes in the order specified may result in extended diagnostic time, incorrect diagnosis and incorrect parts Replacement.

SRS Diagnostic System Check

Step	Action	Yes	No
1	Note the "AIR BAG" warning lamp when ignition switch is turned "ON." Does the "AIR BAG" warning lamp flash seven (7) times?	Go to Step 2	Go to Step 3
2	Note the "AIR BAG" warning lamp after it flashed 7 times. Does the "AIR BAG" warning lamp go "OFF"?	Go to Step 4	Go to Step 5
3	Note the "AIR BAG" warning lamp when ignition switch is turned "ON." Does the "AIR BAG" warning lamp come "ON" steady?	Go to Chart B.	Go to Chart C.
4	1. Ignition switch "OFF." 2. Connect a scan tool to data link connector. 3. Follow direction given in the scan tool instruction manual. 4. Ignition switch "ON." 5. Request the SRS diagnostic trouble code display recode all history diagnostic trouble code(s) specify as such, on repair order. Is diagnostic trouble code(s) displayed?	Ignition switch "OFF." When DTC 71 is set, go to DTC 71 chart. For all other history codes refer to "Diagnostics Aids" for that specific DTC. A history DTC indicates the malfunction has been repaired or is intermittent.	SRS is functional and free of malfunctions, no further diagnosis is required. If scan tool indicates "No Data Received," refer to chassis electrical section.
5	1. Ignition switch "OFF." 2. Connect a scan tool to data link connector. 3. Follow directions as given in the scan tool instruction manual. 4. Ignition switch "ON." 5. Request the SRS diagnostic trouble code display, recode all diagnostic trouble code(s), specifying as current or history on repair order. Is diagnostic trouble code(s) displayed?	Ignition switch "OFF." When DTC 53 is set, go to DTC 53 chart. When DTC 51 is set, go to DTC 51 chart. When DTC 19 is set, go to DTC 19 chart. When DTC 25 is set, go to DTC 25 chart. Diagnose remaining current DTCs from lowest to highest. When only history DTCs exist, Refer to "Diagnostics Aids" for that specific DTC. A history DTC indicates the malfunction has been repaired or is intermittent.	If scan tool indicates "No Data Received," refer to chassis electrical section.

Chart A SDM Integrity Check

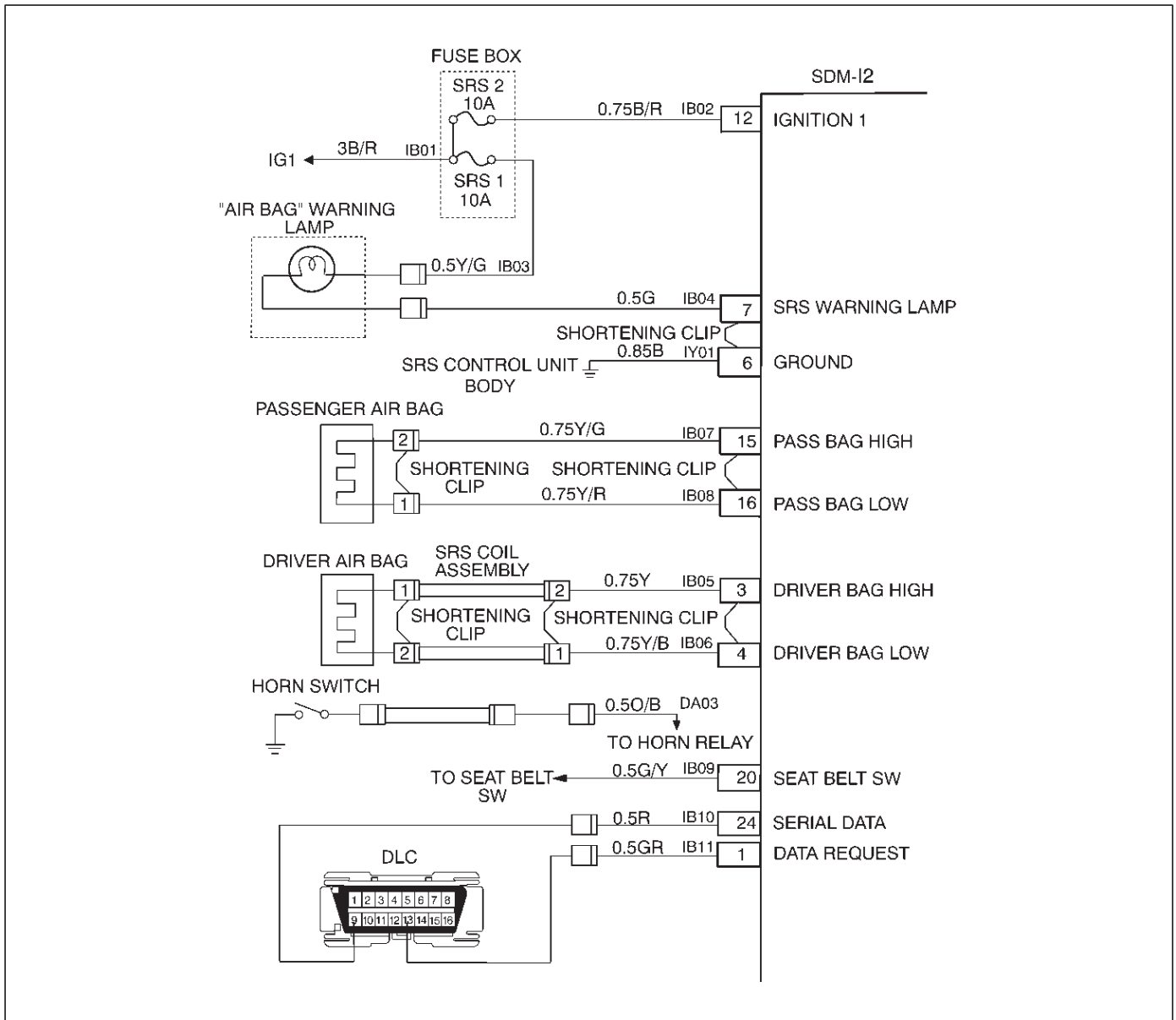

D09RX001

Circuit Description:

When the Sensing and Diagnostic Module (SDM) recognizes "ignition 1" voltage, applied to terminals "12", is greater than 9 volts, the "AIR BAG" warning lamp is flashed 7 times to verify operation. At this time the SDM performs "Turn-ON" tests followed by "Continuous Monitoring" tests. When a malfunction is detected, the SDM sets a current diagnostic trouble code and illuminates the "AIR BAG" warning lamp. The SDM will clear current diagnostic trouble codes and move them to a history file when the malfunction is no longer detected and/or the ignition switch is cycled, except for Diagnostic Trouble Codes (DTCs) 51, 53 and 71. DTC 71 can only be cleared using a scan tool "Clear Codes" command in case that the malfunction on DTC 71 has been solved and no DTCs 51 and 53 were remained. DTCs 51, 53 and 71 can not be cleared after a "Clear Codes" command is issued.

Chart Test Description:

Number(s) below refer to step number(s) on the diagnostic chart:

1. This test confirms a current malfunction. If no current malfunction is occurring (history DTC set) the "Diagnostic Aids" for the appropriate diagnostic trouble code should be referenced. The SDM should not be replaced for a history diagnostic trouble code.
2. This test checks for a malfunction introduced into the SRS during the diagnostic process. It is extremely unlikely that a malfunctioning SDM would cause a new malfunction to occur during the diagnostic process.
3. When all circuitry outside the SDM has been found to operate properly, as indicated by the appropriate diagnostic chart, then and only then should the SDM be replaced.

Chart A SDM Integrity Check

WARNING: DURING SERVICE PROCEDURES. BE VERY CAREFUL WHEN HANDLING A SENSING AND DIAGNOSTIC MODULE (SDM). NEVER STRIKE OR JAR THE SDM. NEVER POWER UP THE SRS WHEN THE SDM IS NOT RIGIDLY ATTACHED TO THE VEHICLE. ALL SDM AND MOUNTING BRACKET FASTENERS MUST BE CAREFULLY TORQUED AND THE ARROW MUST BE POINTING TOWARD THE FRONT OF THE VEHICLE TO ENSURE PROPER OPERATION OF THE SRS. THE SDM COULD BE ACTIVATED WHEN POWERED WHILE NOT RIGIDLY ATTACHED TO THE VEHICLE WHICH COULD CAUSE DEPLOYMENT AND RESULT IN PERSONAL INJURY.

Step	Action	Yes	No
1	<p>1. This chart assumes that the "SRS Diagnostic System Check" and either a symptom chart or a diagnostic trouble code chart diagnosis have been performed. When all circuitry outside the SDM has been found to operate properly, as indicated by the appropriate diagnostic chart, and the symptom or DTC remains current, the following diagnostic procedures must be performed to verify the need for SDM Replacement.</p> <p>2. Ignition switch "OFF."</p> <p>3. Reconnect all SRS components, ensure all components are properly mounted.</p> <p>4. Ensure the ignition switch has been "OFF" for at least 15 seconds.</p> <p>5. Note "AIR BAG" warning lamp as ignition switch is turned "ON."</p> <p>Does warning lamp flash 7 times then go "OFF"?</p>	<p>The symptom or DTC is no longer occurring.</p> <p>Clear SRS diagnostic trouble codes.</p> <p>Repeat the "SRS Diagnostic System Check."</p>	<p>Go to Step 2</p>
2	<p>Using a scan tool, request diagnostic trouble code display.</p> <p>Is the same symptom or DTC occurring as was when the "SRS Diagnostic System Check" was first performed?</p>	<p>Ignition switch "OFF."</p> <p>Go to the appropriate chart for the indicated malfunction.</p>	<p>Go to Step 3</p>
3	<p>1. Clear "SRS Diagnostic Trouble Codes."</p> <p>2. Ignition switch "OFF" for at least two minutes.</p> <p>3. Note "AIR BAG" warning lamp as ignition switch is turned "ON."</p> <p>Does warning lamp flash 7 times then go "OFF"?</p>	<p>SRS is functional and free of malfunctions.</p> <p>No further diagnosis is required.</p> <p>Go to Step 4</p>	<p>Ignition switch "OFF."</p> <p>Replace SDM.</p> <p>Go to Step 4</p>
4	<p>Reconnect all SRS components, ensure all components are properly mounted.</p> <p>Was this step finished?</p>	<p>Repeat the "SRS Diagnostic System Check."</p>	<p>Go to Step 4</p>

Chart B "AIR BAG" Warning Lamp Comes "ON" Steady

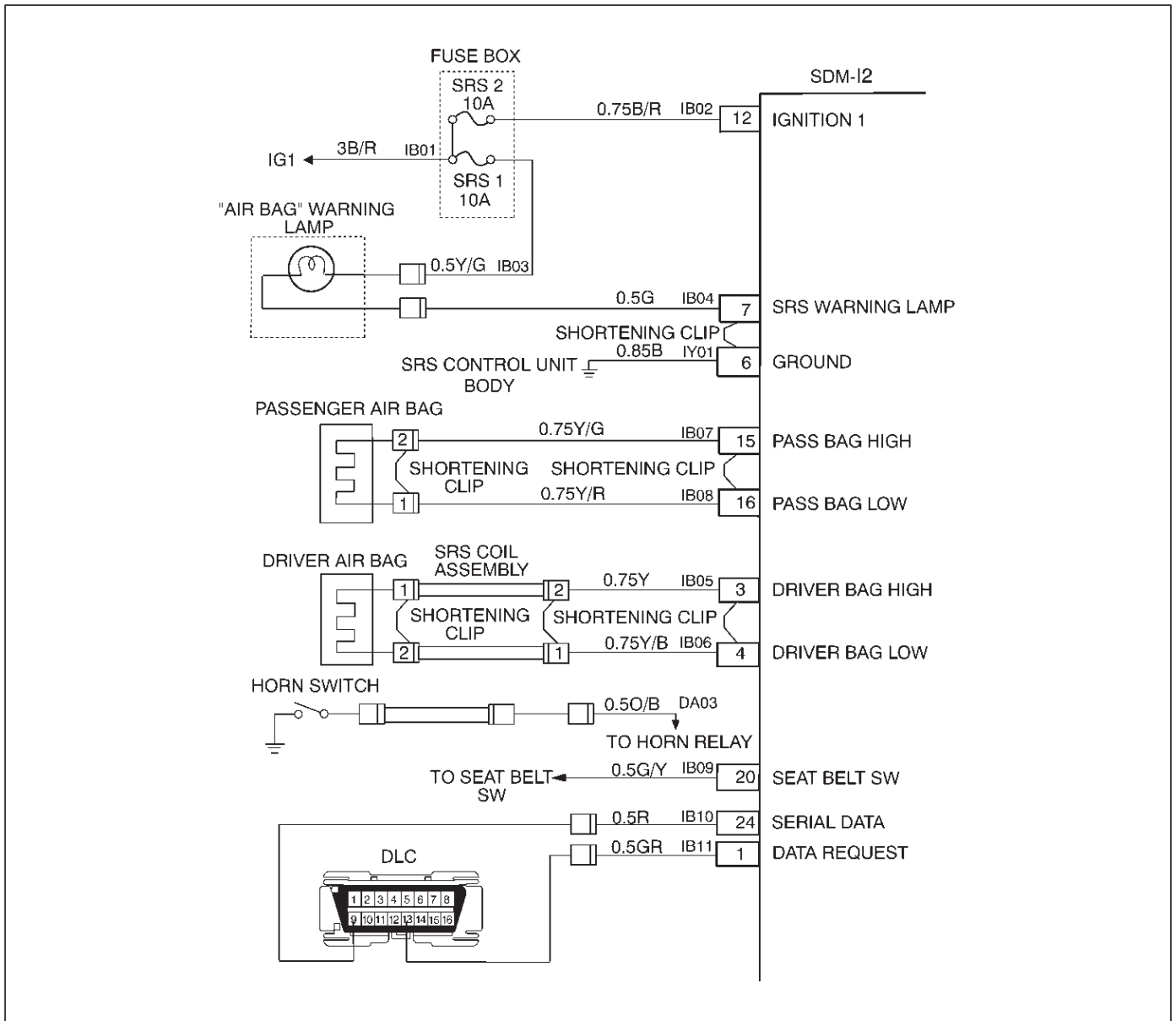

D09RX001

Circuit Description:

When the ignition switch is first turned "ON", "ignition 1" voltage is applied from the "SRS-1" fuse to "AIR BAG", warning lamp which is connected to "Supplemental Restraint System (SRS) warning lamp", terminal "7". The "SRS-2" fuses apply system voltage to the "ignition 1" inputs, terminals "12". The Sensing and Diagnostic Module (SDM) responds by flashing the "AIR BAG" warning lamp 7 times. If "ignition 1" voltage is less than 9 volts, the "AIR BAG" warning lamp will come "ON" solid with no DTCs set.

Chart Test Description:

Number (s) below refer to step number (s) on the diagnostic chart.

2. This test checks for an open in the "ignition 1" circuit to the SDM.
3. This test checks for the voltage of "ignition 1."
4. This test determines whether the malfunction is a short to ground in Circuit IB04 – GREEN.

Chart B “AIR BAG” Warning Lamp Comes “ON” Steady

Step	Action	Yes	No
1	<p>1. When measurements are requested in this chart use J-39200 DVM with correct terminal adapter from J-35616-A.</p> <p>2. Ignition switch “OFF.”</p> <p>3. Connect scan tool to data link connector, Follow directions as given in the scan tool instruction manual.</p> <p>4. Ignition switch “ON.”</p> <p>5. Request SRS diagnostic trouble code display.</p> <p>Does scan tool indicate “No Data Received”?</p>	Go to Step 2	Go to Step 3
2	<p>1. Ignition switch “OFF.”</p> <p>2. Inspect SDM harness connector connection to SDM.</p> <p>Is it securely connected to the SDM?</p>	<p>Ignition switch “OFF.”</p> <p>Replace SDM.</p> <p>Go to Step 5</p>	<p>Connect SDM securely to de-activate shorting clip in SDM harness connector.</p> <p>Go to Step 5</p>
3	<p>Using scan tool, request SRS data list.</p> <p>Is “ignition” more than 9 volts?</p>	Go to Step 4	<p>Ignition switch “OFF.”</p> <p>Replace SDM.</p> <p>Go to Step 5</p>
4	<p>1. Ignition switch “OFF.”</p> <p>2. Disconnect SRS coil and passenger air bag assemblies. Yellow 2-pin connectors located at base of steering column and behind the glove box assembly.</p> <p>3. Disconnect SDM.</p> <p>4. Measure resistance from SDM harness connector terminal “6” to ground.</p> <p>Does J-39200 display “OL” (infinite)?</p>	Go to Chart A.	<p>Replace SRS harness.</p> <p>Go to Step 5</p>
5	<p>Reconnect all SRS components, ensure all components are properly mounted.</p> <p>Was this step finished?</p>	Repeat the “SRS Diagnostic System Check.”	Go to Step 5

Chart C "AIR BAG" Warning Lamp Does Not Comes "ON" Steady

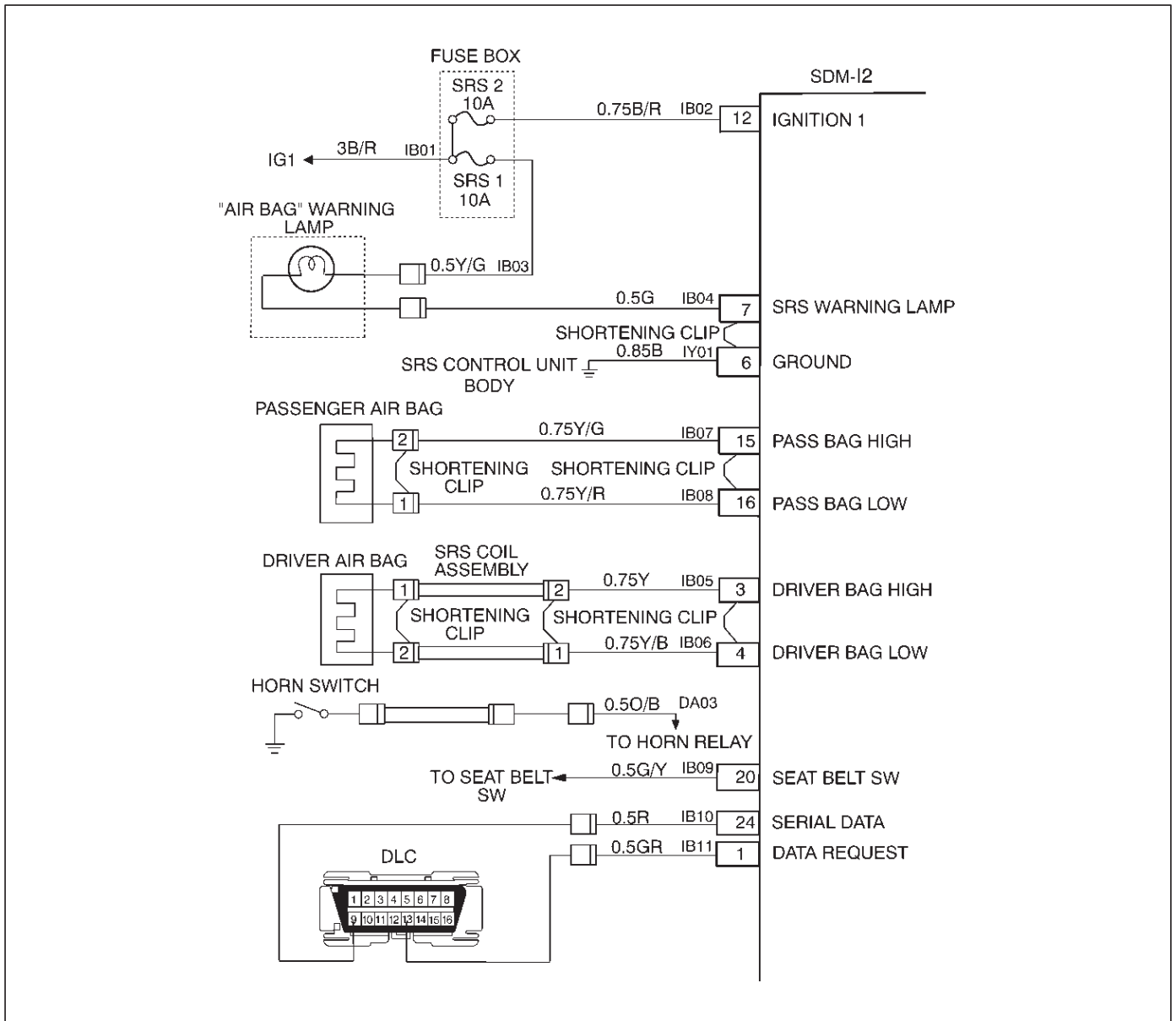

D09RX001

Circuit Description:

When the ignition switch is first turned "ON", "ignition 1" voltage is applied from the "SRS-1" fuse to the "AIR BAG" warning lamp which is connected to "Supplemental Restraint System (SRS) warning lamp", terminal "7". The "SRS-2" fuse apply system voltage to the "ignition 1" inputs, terminals "12". The Sensing and Diagnostic Module (SDM) responds by flashing the "AIR BAG" warning lamp seven times. If "ignition 1" voltage is more than 16 volts, the "AIR BAG" warning lamp will be still "OFF" solid with no DTCs set.

Chart Test Description:

Number(s) below refer to step number(s) on the diagnostic chart:

1. This test decides whether power is available to SDM warning lamp power feed circuit.
2. This test determines whether the voltage is present in the warning lamp circuit.
3. This test determines if the malfunction is in the instrument cluster.
4. This test checks for open in the warning lamp circuitry.
5. This test isolates the IB04-GREEN circuit and checks for a short in the IB04-GREEN circuit to B+.
8. This test checks for a short from the SDM warning lamp power feed circuit to ground.
9. This test determines whether the short to ground is due to a short in the wiring.

Chart C “AIR BAG” Warning Lamp Does Not Comes “ON” Steady

Step	Action	Yes	No
1	<p>1. When measurements are requested in this chart use J-39200 DVM with correct terminal adapter from J-35616-A.</p> <p>2. Ignition switch “OFF.”</p> <p>3. Remove and inspect “SRS-1” fuse to the “AIR BAG” warning lamp.</p> <p>Is fuse good?</p>	Go to Step 2	Go to Step 7
2	<p>1. Ignition switch “OFF.”</p> <p>2. Disconnect SRS coil and passenger air bag assemblies. Yellow 2-pin connectors located at base of steering column and behind the glove box assembly.</p> <p>3. Disconnect SDM.</p> <p>4. Ignition switch “ON.”</p> <p>5. Measure voltage on SDM harness connector from terminal “7” to terminal “6” (ground).</p> <p>Is system voltage present on terminal “7”?</p>	Go to Step 4	Go to Step 3
3	<p>1. Ignition switch “OFF.”</p> <p>2. Remove instrument meter cluster.</p> <p>3. Check for proper connection to instrument cluster at IB04-GRN terminal.</p> <p>4. If OK, then remove and inspect “AIR BAG” bulb.</p> <p>Is bulb good?</p>	Go to Step 5	Replace bulb. Go to Step 6
4	<p>1. Ignition switch “OFF.”</p> <p>2. Disconnect instrument meter cluster harness connector.</p> <p>3. Ignition switch “ON.”</p> <p>4. Measure voltage on SDM harness connector from terminal “7” to terminal “6” (ground).</p> <p>Is voltage 1 volt or less?</p>	Go to Chart A.	Replace SRS harness. Go to Step 6
5	<p>1. Install bulb.</p> <p>2. Measure resistance from instrument meter cluster harness connector IB04-GRN terminal to SDM harness connector terminal “7”.</p> <p>Is resistance 5.0 ohms or less?</p>	Service instrument meter cluster. Go to Step 6	Replace SRS harness. Go to Step 6
6	<p>Reconnect all SRS components, ensure all components are properly mounted.</p> <p>Was this step finished?</p>	Repeat the “SRS Diagnostic System Check.”	Go to Step 6
7	<p>Perform chart C.</p> <p>Were you sent here from chart C?</p>	Go to Step 8	Go to Step 1
8	<p>1. Replace “SRS-1” meter fuse.</p> <p>2. Ignition switch “ON” wait 10 seconds then ignition switch “OFF.”</p> <p>3. Remove and inspect “SRS-1” fuse.</p> <p>Is fuse good?</p>	Install “SRS-1” fuse. Go to Step 10	Go to Step 9

9J1-14 RESTRAINT CONTROL SYSTEM**Chart C "AIR BAG" Warning Lamp Does Not Comes "ON" Steady (Cont'd)**

Step	Action	Yes	No
9	<ol style="list-style-type: none">1. Disconnect SRS coil and passenger air bag assemblies. Yellow 2-pin connectors located at base of steering column and behind the glove box assembly.2. Disconnect SDM.3. Replace "SRS-1" fuse.4. Ignition switch "ON" wait to 10 seconds.5. Ignition switch "OFF".6. Remove and inspection "SRS-1" fuse. Is fuse good?	Install "SRS-1" fuse. Go to Chart A.	Replace SRS harness. Replace "SRS-1" fuse. Go to Step 10
10	Reconnect all SRS components, ensure all components are properly mounted. Was this step finished?	Repeat the "SRS Diagnostic System Check."	Go to Step 10

DTC 15 Passenger Deployment Loop Resistance High

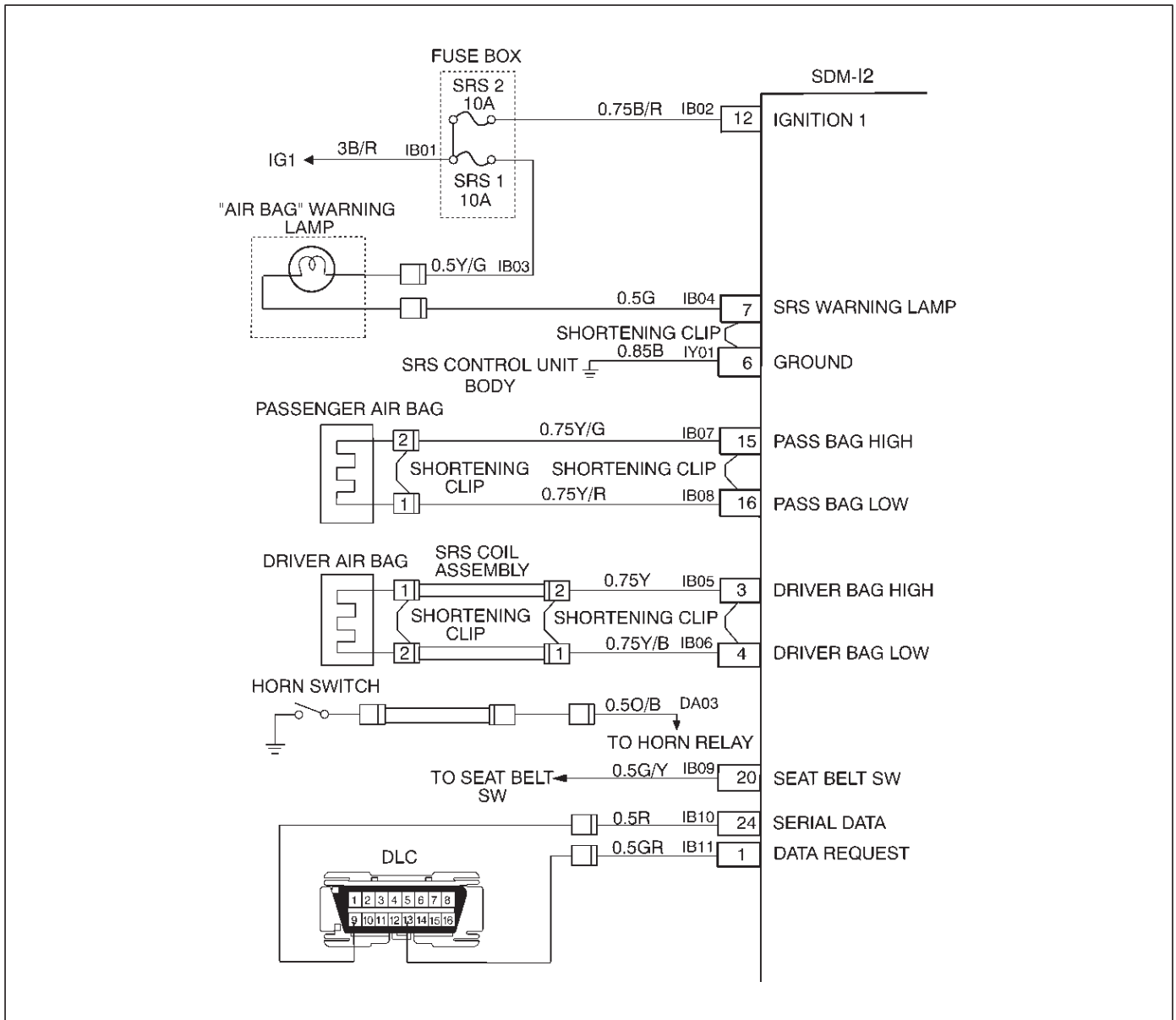

D09RX001

Circuit Description:

When the ignition switch is turned "ON", the Sensing and Diagnostic Module (SDM) will perform tests to diagnose critical malfunctions within itself. Upon passing these tests "ignition 1", and deployment loop voltages are measured to ensure they are within their respective normal voltage ranges. The SDM then proceeds with the "Resistance Measurement Test". "Passenger Bag Low" terminal "16" is grounded through a resistor and the passenger current source connected to "Passenger Bag High" terminal "15" allows a known amount of current to flow. By monitoring the voltage difference between "Passenger Bag High" and "Passenger Bag Low" the SDM calculates the combined resistance of the passenger air bag assembly, harness wiring Circuits(CKTs) IB07-YELLOW/GREEN and IB08-YELLOW/RED connector terminal contact.

DTC Will Set When:

The combined resistance of the passenger air bag assembly, harness wiring CKTs IB07-YELLOW/GREEN and IB08-YELLOW/RED, and connector terminal contact is above a specified value. This test is run once each ignition cycle during the "Resistance Measurement Test" when:

1. No "higher priority faults" are detected during "Turn-ON."
2. "Ignition 1" voltage is in the specified value.

Action Taken:

SDM turns "ON" the "AIR BAG" warning lamp and sets a diagnostic trouble code.

DTC Will Clear When:

The ignition switch is turned "OFF."

9J1-16 RESTRAINT CONTROL SYSTEM

DTC Chart Test Description:

Number(s) below refer to step number(s) on the diagnostic chart:

2. This test determines whether the malfunction is in the Sensing and Diagnostic Module (SDM).
3. This test verifies proper connection of the yellow 2-pin connector.
4. This test checks for proper contact and/or corrosion of the yellow 2-pin connector terminals.
5. The test checks for a malfunctioning passenger air bag assembly.
6. This test determines whether the malfunction is due to high resistance in the wiring.

Diagnostic Aids:

An intermittent condition is likely to be caused by a poor connection at the passenger air bag assembly harness connector terminals "1" and "2", SDM terminal "15" and "16", or a poor wire to terminal connection in Circuits(CKTs) IB07-YELLOW/GREEN and IB08-YELLOW/RED. This test for this diagnostic trouble code is only run while the "AIR BAG" warning lamp is performing the bulb check, unless Diagnostic Trouble Code (DTC) 17 or DTC 26 is detected. When a scan tool "Clear Codes" command is issued and the malfunction is still present, the DTC will not reappear until the next ignition cycle.

DTC 15 Passenger Deployment Loop Resistance High

Step	Action	Yes	No
1	Was the "SRS Diagnostic System Check" performed?	Go to Step 2	Go to the "SRS Diagnostic System Check."
2	1. When measurements are requested in this chart use J-39200 DVM with correct terminal adapter from J-35616-A. 2. Use scan tool data list function, read and record the passenger deployment loop resistance. Is passenger resist more than 2.9 ohms?	Go to Step 3	Go to Chart A.
3	1. Ignition switch "OFF." 2. Make sure the passenger air bag assembly yellow 2-pin connector located behind the glove box assembly is seated properly. Is the yellow 2-pin connector connected properly?	Go to Step 4	Seat passenger air bag assembly yellow 2-pin connector properly. Go to Step 7
4	1. Disconnect and inspect the passenger air bag assembly yellow 2-pin connector located behind the glove box assembly. 2. If OK, reconnect the passenger air bag assembly 2-pin connector. 3. Ignition switch "ON." Is DTC 15 current?	Go to Step 5	Ignition switch "OFF." Go to Step 7
5	1. Ignition switch "OFF." 2. Disconnect SRS coil and passenger air bag 2-pin connectors located at the base of the steering column and behind the glove box assembly. 3. Connect J-41433 SRS driver / passenger load tool and appropriate adapters to SRS coil and passenger air bag assembly harness connectors. 4. Ignition switch "ON." Is DTC 15 current?	Go to Step 6	Ignition switch "OFF." Replace the passenger air bag assembly. Go to Step 7
6	1. Ignition switch "OFF." 2. There has been an increase in the total circuit resistance of the passenger inflator deployment loop. 3. Use the high resolution ohmmeter mode of the DVM while checking CKTs IB07-YEL/GRN and IB08-YEL/RED, and SDM connector terminal "15" and "16" to locate the root cause. Was a fault found?	Replace SRS harness. Go to Step 7	Go to Chart A.
7	1. Reconnect all components ensure all component are properly mounted. 2. Clear diagnostic trouble codes. Was this step finished?	Repeat the "SRS Diagnostic System Check."	Go to Step 7

DTC 16 Passenger Deployment Loop Resistance Low

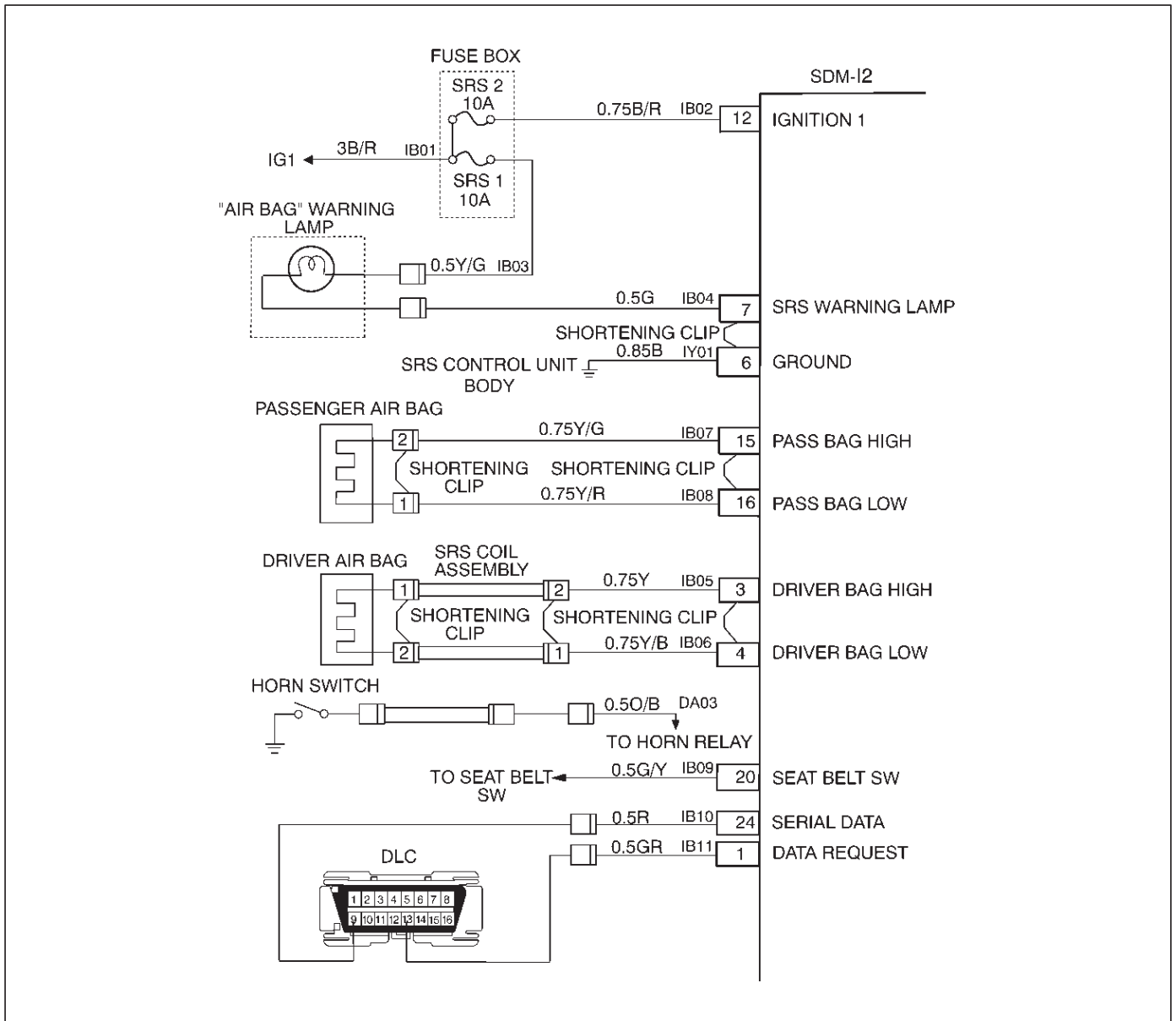

D09RX001

Circuit Description:

When the ignition switch is turned “ON”, the Sensing and Diagnostic Module (SDM) will perform tests to diagnose critical malfunctions within itself. Upon passing these tests “ignition 1”, and deployment loop voltages are measured to ensure they are within their respective normal voltage ranges. The SDM then proceeds with the “Resistance Measurement Test”. “Passenger Bag Low” terminal “16” is grounded through a resistor and the passenger current source connected to “Passenger Bag High” terminal “15” allows a known amount of current to flow. By monitoring the voltage difference between “Passenger Bag High” and “Passenger Bag Low”, the SDM calculates the combined resistance of the passenger air bag assembly, harness wiring Circuits(CKTs) IB07-YELLOW/GREEN and IB08-YELLOW/RED connector terminal contact.

DTC Will Set When:

The combined resistance of the passenger air bag assembly, harness wiring CKTs IB07-YELLOW/GREEN and IB08-YELLOW/RED, and connector terminal contact is above a specified value. This test is run once each ignition cycle during the “Resistance Measurement Test” when:

- 1.No “higher priority faults” are detected during “Turn-ON”,
2. “Ignition 1” voltage is in the specified value.

Action Taken:

SDM turns “ON” the “AIR BAG” warning lamp and sets a diagnostic trouble code.

DTC Will Clear When:

The ignition switch is turned “OFF.”

DTC Chart Test Description:

Number(s) below refer to step number(s) on the diagnostic chart:

2. This test determines whether the malfunction is in the Sensing and Diagnostic Module (SDM).
3. This test verifies connection of the yellow 2-pin connector.
4. This test checks for proper operation of the shorting clip in the yellow 2-pin connector.
5. The test checks for a malfunction passenger air bag assembly.
6. This test determines whether the malfunctioning is due to shorting in the wiring.

Diagnostic Aids:

An intermittent condition is likely to be caused by a short between Circuits(CKTs) IB07-YELLOW/GREEN and IB08-YELLOW/RED, or a malfunctioning shorting clip on the passenger air bag assembly which would require replacement of the air bag assembly. The test for this diagnostic trouble code is only run while "AIR BAG" warning lamp is performing the bulb check, unless Diagnostic Trouble Code (DTC) 17 or DTC 26 is detected. When a scan tool "Clear Codes" command is issued and the malfunction is still present, the DTC will not reappear until the next ignition cycle.

9J1-20 RESTRAINT CONTROL SYSTEM

DTC 16 Passenger Deployment Loop Resistance Low

Step	Action	Yes	No
1	Was the "SRS Diagnostic System Check" performed?	Go to Step 2	Go to the "SRS Diagnostic System Check."
2	1. When measurements are requested in this chart use J-39200 DVM with correct terminal adapter from J-35616-A. 2. Using scan tool data list function, read and record the passenger deployment loop resistance. Is passenger resist. less than 1.4 ohms?	Go to Step 3	Go to Chart A.
3	1. Ignition switch "OFF." 2. Make sure the passenger air bag assembly yellow 2-pin connector located behind the glove box assembly is seated properly. Is the yellow 2-pin connector connected properly?	Go to Step 4	Seat passenger air bag assembly yellow 2-pin connector properly. Go to Step 7
4	1. Disconnect and inspect the passenger air bag assembly yellow 2-pin connector located behind the glove box assembly. 2. If OK, reconnect the passenger air bag assembly 2-pin connector. 3. Ignition switch "ON." Is DTC 16 current?	Go to Step 5	Ignition switch "OFF."Go to Step 7
5	1. Ignition switch "OFF." 2. Disconnect SRS coil and passenger air bag 2-pin connectors located at the base of the steering column and behind the glove box assembly. 3. Connect J-41433 SRS driver / passenger load tool and appropriate adapters to SRS coil and passenger air bag assembly harness connectors. 4. Ignition switch "ON." Is DTC 16 current?	Go to Step 6.	Ignition switch "OFF." Replace the passenger air bag assembly. Go to Step 7
6	1. Ignition switch "OFF." 2. There has been a decrease in the total circuit resistance of the passenger inflator deployment loop. 3. Use the high resolution ohmmeter mode of the DVM while checking CKTs IB07-YEL/GRN and IB08-YEL/RED, and SDM connector terminal "15" and "16" to locate the root cause. Was a fault found?	Replace SRS harness. Go to Step 7	Go to Chart A.
7	1. Reconnect all components, ensure all component are properly mounted. 2. Clear diagnostic trouble codes. Was this step finished?	Repeat the "SRS Diagnostic System Check."	Go to Step 7

DTC 17 Passenger Deployment Loop Open

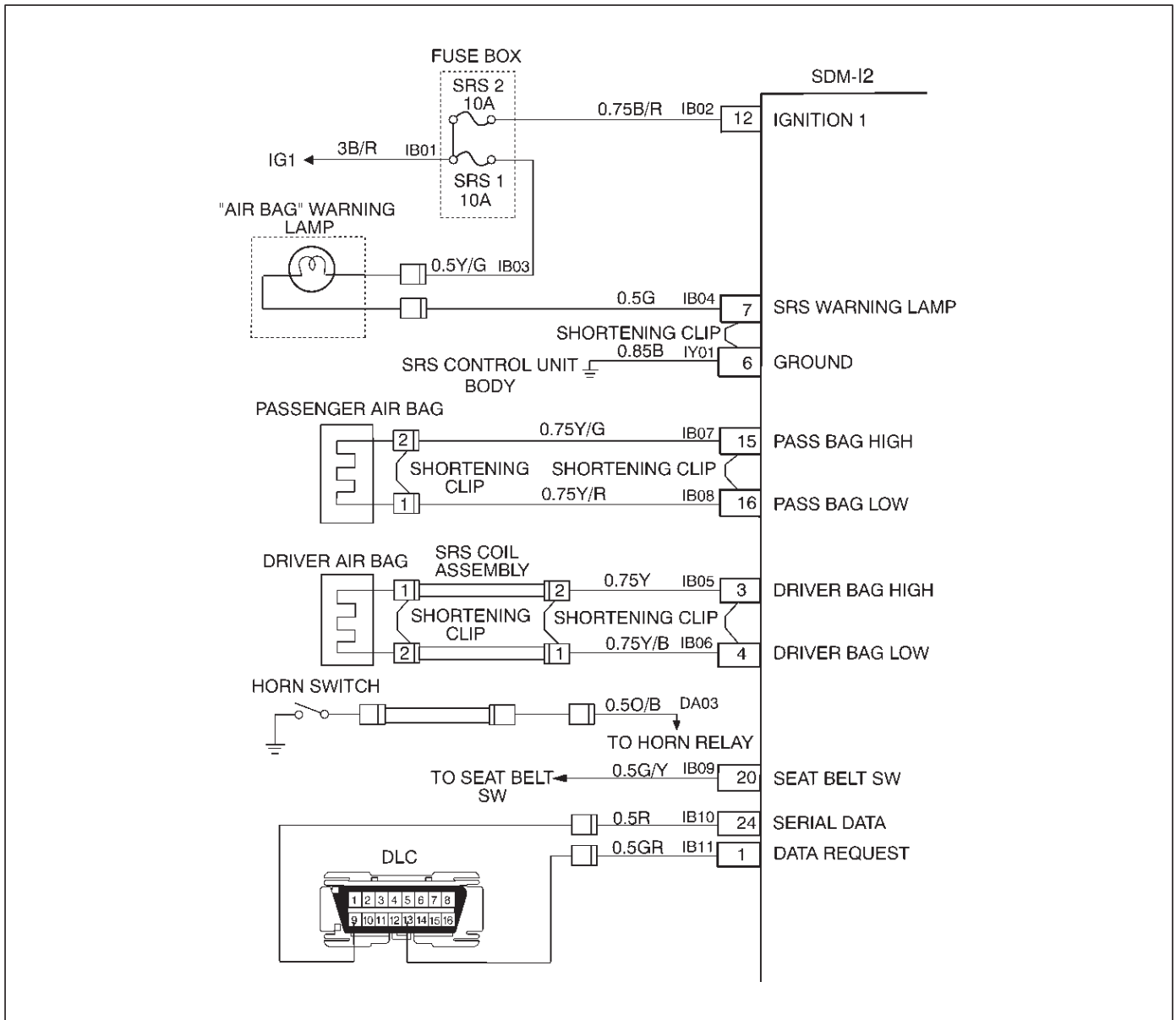

D09RX001

Circuit Description:

When the ignition switch is turned "ON", the Sensing and Diagnostic Module (SDM) will perform tests to diagnose critical malfunctions within itself. Upon passing these tests, "ignition 1", and deployment loop voltages are measured to ensure they are within their respective normal voltage ranges. During "Continuous Monitoring" diagnostics, a fixed amount of current is flowing in the deployment loop. This produces proportional voltage drops in the loop. By monitoring the voltage difference between "Passenger Bag High" and "Passenger Bag Low", the SDM calculates the combined resistance of the passenger air bag assembly, harness wiring Circuits(CKTs) IB07-YELLOW/GREEN and IB08-YELLOW/RED, and connector terminal contact.

DTC Will Set When:

The voltage difference between "Passenger Bag High" terminal "15" and "Passenger Bag Low" terminal "16" is

above or equal to a specified value for 500 milliseconds during "Continuous Monitoring".

Action Taken:

SDM turns "ON" the "AIR BAG" warning lamp and sets a diagnostic trouble code.

DTC Will Clear When:

The voltage difference between "Passenger Bag High" terminal "15" and "Passenger Bag Low" terminal "16" is below a specified value for 500 milliseconds during "Continuous Monitoring".

DTC Chart Test Description:

Number(s) below refer to step number(s) on the diagnostic chart:

2. This test determines whether the malfunction is in the Sensing and Diagnostic Module (SDM).

9J1-22 RESTRAINT CONTROL SYSTEM

3. This test verifies proper connection of the yellow 2-pin connector.
4. This test checks for proper contact and/or corrosion of the shorting clip in the yellow 2-pin connector terminals.
5. The test checks for a malfunctioning passenger air bag assembly.
6. This test determines whether there is an open in the wiring.

Diagnostic Aids:

An intermittent condition is likely to be caused by a poor connection at the passenger air bag assembly harness connector terminals "1" and "2," SDM terminals "15" and "16," or an open in Circuits IB07-YELLOW/GREEN and IB08-YELLOW/RED.

DTC 17 Passenger Deployment Loop Open

Step	Action	Yes	No
1	Was the "SRS Diagnostic System Check" performed?	Go to Step 2	Go to the "SRS Diagnostic System Check."
2	<ol style="list-style-type: none"> 1. When measurements are requested in this chart use J-39200 DVM with correct terminal adapter from J-35616-A. 2. Using scan tool data list function, read and record the passenger differential voltage. Is passenger differential voltage. more than 4.25 volts?	Go to Step 3	Go to Chart A.
3	<ol style="list-style-type: none"> 1. Ignition switch "OFF." 2. Make sure the passenger air bag assembly yellow 2-pin connector located behind the glove box assembly is seated properly. Is the yellow 2-pin connector connected properly?	Go to Step 4	Seat passenger air bag assembly yellow 2-pin connector properly. Go to Step 7
4	<ol style="list-style-type: none"> 1. Disconnect and inspect the passenger air bag assembly yellow 2-pin connector located behind the glove box assembly. 2. If OK, reconnected the passenger air bag assembly yellow 2-pin connector. 3. Ignition switch "ON." Is DTC 17 current?	Go to Step 5	Ignition switch "OFF." Go to Step 7
5	<ol style="list-style-type: none"> 1. Ignition switch "OFF." 2. Disconnect SRS coil and passenger air bag assembly yellow 2-pin connectors located at the base of the steering column and behind the glove box assembly. 3. Connect J-41433 SRS driver / passenger load tool and appropriate adapters to SRS coil and passenger air bag assembly harness connectors. 4. Ignition switch "ON." Is DTC 17 current?	Go to Step 6	Ignition switch "OFF." Replace the passenger air bag assembly. Go to Step 7
6	<ol style="list-style-type: none"> 1. Ignition switch "OFF." 2. There has been an open circuit in the passenger inflator deployment loop. 3. Use the high resolution ohmmeter mode of the DVM while checking CKTs IB07-YEL/GRN and IB08-YEL/RED, and SDM connector terminal "15" and "16" to locate the root cause. Was a fault found?	Replace SRS harness. Go to Step 7	Go to Chart A.
7	<ol style="list-style-type: none"> 1. Reconnect all components ensure all component are properly mounted. 2. Clear diagnostic trouble codes. Was this step finished?	Repeat the "SRS Diagnostic System Check."	Go to Step 7

DTC 18 Passenger Deployment Loop Short To Ground

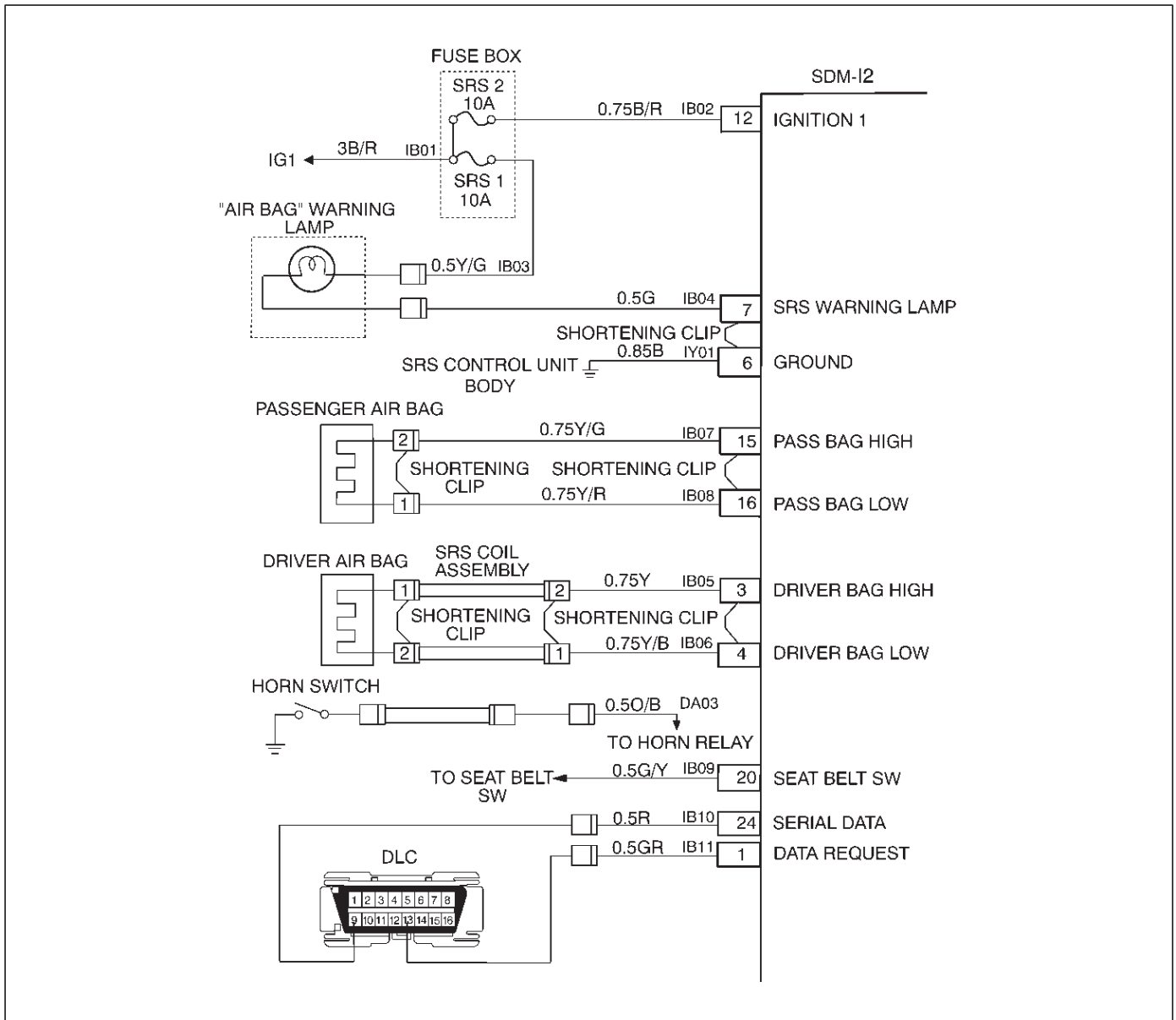

D09RX001

Circuit Description:

When the ignition switch is turned "ON", the Sensing and Diagnostic Module (SDM) will perform tests to diagnose critical malfunctions within itself. Upon passing these tests, "ignition 1", and deployment loop voltages are measured to ensure they are within their respective normal voltage ranges.

The SDM monitors the voltages at "Driver Bag Low" terminal "4" and "Passenger Bag Low" terminal "16" to detect short to ground in the air bag assembly circuits.

DTC Will Set When:

Neither of the two air bag assemblies is open. "Ignition 1" is within the normal operating voltage range. Once these conditions are met and the voltage at "Passenger Bag Low" is below a specified value, Diagnostic Trouble Code (DTC) 18 will set. This test is run once each ignition cycle and "Continuous Monitoring".

Action Taken:

SDM turns "ON" the "AIR BAG" warning lamp and sets a diagnostic trouble code.

DTC Will Clear When:

This malfunction is no longer occurring and the ignition switch is turned "OFF".

DTC Chart Test Description:

Number(s) below refer to circled number(s) on the diagnostic chart:

2. This test determines whether the SDM is malfunctioning.
3. This test isolates the malfunction to one side of the passenger air bag assembly yellow 2-pin connector behind glove box compartment.
4. This test determines whether the malfunction is in Circuit(CKT) IB07-YELLOW/GREEN.

9J1-24 RESTRAINT CONTROL SYSTEM

5. This test determines whether the malfunction is in CKT IB08-YELLOW/RED.

Inspect CKTs IB07-YELLOW/GREEN and IB08-YELLOW/RED carefully for cutting or chafing. If the wiring pigtail of the passenger air bag assembly is damaged, the component must be replaced.

Diagnostic Aids:

An intermittent condition is likely to be caused by a short to ground in the passenger air bag assembly circuit.

DTC 18 Passenger Deployment Loop Short To Ground

Step	Action	Yes	No
1	Was the "SRS Diagnostic System Check" performed?	Go to Step 2	Go to the "SRS Diagnostic System Check."
2	<ol style="list-style-type: none"> When measurements are requested in this chart use J-39200 DVM with correct terminal adapter from J-35616-A. Ignition switch "OFF." Connect scan tool data link connector. Follow directions as given in the scan tool operator's manual. Ignition switch "ON." Read passenger sense LO. Is passenger sense LO less than 1.5 volts?	Go to Step 3	Go to Chart A.
3	<ol style="list-style-type: none"> Ignition switch "OFF." Disconnect passenger air bag assembly yellow 2-pin connector behind the glove box assembly. Leave driver air bag assembly connected. Connect SRS driver / passenger load tool J-41433 and appropriate adapter to passenger air bag assembly harness connector. Ignition switch "ON." Is DTC 18 current?	Go to Step 4	Ignition switch "OFF." Replace passenger air bag assembly. Go to Step 6
4	<ol style="list-style-type: none"> Ignition switch "OFF." Disconnect SRS driver / passenger load tool. Measure resistance on SDM harness connector from terminal "15" to terminal "6" (ground). Does J-39200 display "OL" (infinite)?	Go to Step 5	Replace SRS harness. Go to Step 6
5	Measure resistance on SDM harness connector from terminal "6" "16" to terminal (ground). Does J-39200 display "OL" (infinite)?	Go to Chart A.	Replace SRS harness. Go to Step 6
6	<ol style="list-style-type: none"> Reconnect all components, ensure all component are properly mounted. Clear diagnostic trouble codes. Was this step finished?	Repeat the "SRS Diagnostic System Check."	Go to Step 6

DTC 19 Passenger Deployment Loop Short To Voltage

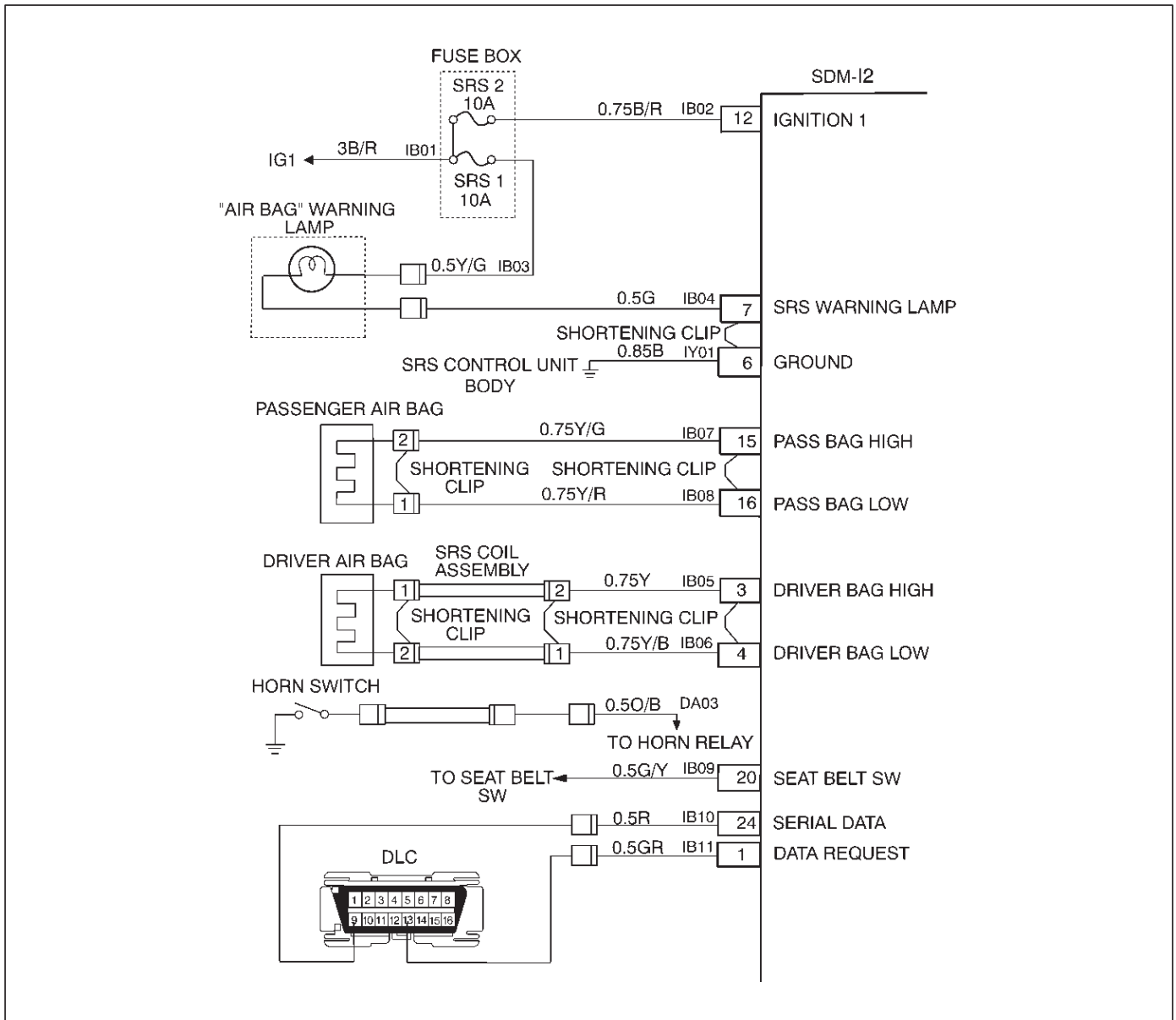

D09RX001

Circuit Description:

When the ignition switch is turned "ON", the Sensing and Diagnostic Module (SDM) will perform tests to diagnose critical malfunctions within itself. Upon passing these tests, "ignition 1", and deployment loop voltages are measured to ensure they are within their respective normal voltage ranges.

The SDM monitors the voltages at "Driver Bag Low" terminal "4" and "Passenger Bag Low" terminal "16" to detect short to B+ in the air bag assembly circuits.

DTC Will Set When:

"Ignition 1" is within the normal operating voltage range. Once these conditions are met and the voltage at "Passenger Bag Low" is above a specified value, Diagnostic Trouble Code (DTC) 19 will set. This test is run once each ignition cycle and "Continuous Monitoring".

Action Taken:

SDM turns "ON" the "AIR BAG" warning lamp and sets DTC 19 and also DTC 71.

DTC Will Clear When:

The SDM is replaced.

DTC Chart Test Description:

Number(s) below refer to step number(s) on the diagnostic chart:

2. This test determines whether the malfunction is in the SDM.
3. This test isolates the malfunction to one side of the passenger air bag assembly yellow 2-pin connector behind glove box compartment.
4. This test determines whether the malfunction is in Circuit(CKT) IB07-YELLOW/GREEN.

9J1-26 RESTRAINT CONTROL SYSTEM

5. This test determines whether the malfunction is in CKT IB08-YELLOW/RED.

Diagnostic Aids:

An intermittent condition is likely to be caused by a short to B+ in the passenger air bag assembly circuit. Inspect CKTs IB07-YELLOW/GREEN and IB08-YELLOW/RED

carefully for cutting or chafing. If the wiring pigtail of the passenger air bag assembly is damaged, the component must be replaced. A careful inspection of CKT IB07-YELLOW/GREEN and IB08-YELLOW/RED, including the passenger air bag assembly pigtail is essential to ensure that the replacement Sensing and Diagnostic Module (SDM) will not be damaged.

DTC 19 Passenger Deployment Loop Short To Voltage

CAUTION: When DTC 19 has been set, it is necessary to replace the Sensing and Diagnostic Module (SDM). Setting Diagnostic Trouble Code (DTC) 19 and 25 or 51 or 53 will also cause DTC 71 to set. When a scan tool "CLEAR CODES" command is issued and the malfunction is no longer present, DTC 71 will remain current. Ensure that the short to voltage condition is repaired prior to installing a replacement SDM to avoid damaging the SDM.

Step	Action	Yes	No
1	Was the "SRS Diagnostic System Check" performed?	Go to Step 2	Go to the "SRS Diagnostic System Check."
2	<ol style="list-style-type: none"> When measurements are requested in this chart use J-39200 DVM with correct terminal adapter from J-35616-A. Ignition switch "OFF." Connect scan tool data link connector. Follow directions as given in the scan tool operator's manual. Ignition switch "ON." Read passenger sense LO. Is passenger sense LO more than 3.5 volts?	Go to Step 3	Go to Chart A.
3	<ol style="list-style-type: none"> Ignition switch "OFF." Disconnect passenger air bag assembly yellow 2-pin connector behind the glove box assembly. Leave driver air bag assembly connected. Connect SRS driver / passenger load tool J-41433 and appropriate adapter to passenger air bag assembly harness connector. Ignition switch "ON." Is passenger sense LO more than 3.5 volts?	Go to Step 4	Ignition switch "OFF." Replace passenger air bag assembly. Go to Step 6
4	<ol style="list-style-type: none"> Ignition switch "OFF." Disconnect SDM. Disconnect SRS driver / passenger load tool. Measure resistance on SDM harness connector from terminal "15" to terminal "12" (IGNITION 1). Does J-39200 display "0L" (infinite)?	Go to Step 5	Replace SRS harness. Go to Step 6
5	Measure resistance on SDM harness connector from terminal "16" to terminal "12" (IGNITION 1). Does J-39200 display "0L" (infinite)?	Go to Chart A.	Replace SRS harness. Go to Step 6
6	<ol style="list-style-type: none"> Reconnect all components, ensure all component are properly mounted. Ignition switch "ON." Is passenger sense LO less than 3.5 volts?	Ignition switch "OFF." Replace SDM. Go to Step 7	Go to Chart A.
7	<ol style="list-style-type: none"> Reconnect all components, ensure all component are properly mounted. Clear diagnostic trouble codes. Was this step finished?	Repeat the "SRS Diagnostic System Check."	Go to Step 7

DTC 21 Driver Deployment Loop Resistance High

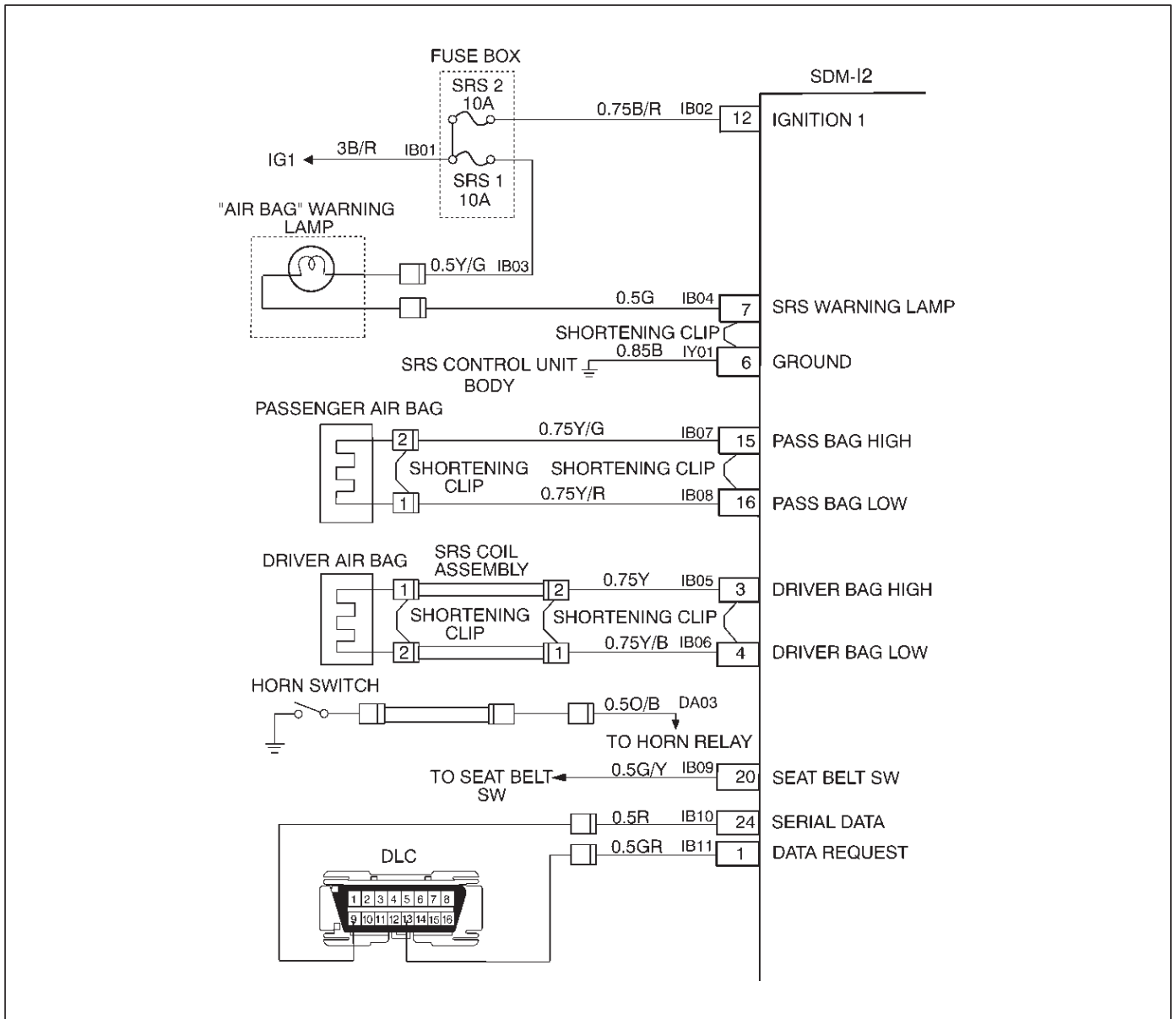

D09RX001

Circuit Description:

When the ignition switch is turned "ON", the Sensing and Diagnostic Module (SDM) will perform tests to diagnose critical malfunctions within itself. Upon passing these tests, "ignition 1", and deployment loop voltages are measured to ensure they are within their respective normal voltage ranges.

The SDM then proceeds with the "Resistance Measurement Test" "Driver Bag Low" terminal "4" is grounded through a current sink and the driver current source connected to "Driver Bag High" terminal "3" allows a known amount of current to flow. By monitoring the voltage difference between "Driver Bag High" and "Driver Bag Low", the SDM calculates the combined resistance of the driver air bag assembly, SRS coil assembly, harness wiring Circuits(CKTs) IB05-YELLOW and IB06-YELLOW/BLACK, and connector terminal contact.

DTC Will Set When:

The combined resistance of the driver air bag assembly, SRS Coil assembly, harness wiring CKTs IB05-YELLOW and IB06-YELLOW/BLACK, and connector terminal contact is above a specified value. This test run once each ignition cycle during the "Resistance Measurement Test" when:

No "higher priority faults" are detected during "Turn-ON"

"Ignition 1" voltage is in the specified value.

Action Taken:

SDM turns "ON" the "AIR BAG" warning lamp and sets DTC 21.

DTC Will Clear When:

The ignition switch is turned "OFF".

9J1-28 RESTRAINT CONTROL SYSTEM

DTC Chart Test Description:

Number(s) below refer to step number(s) on the diagnostic chart:

2. This test determines whether the malfunction is in the Sensing and Diagnostic Module (SDM).
3. This test verifies proper connection of the yellow 2-pin connector at the base of the steering column.
4. This test checks for proper contact and/or corrosion of the 2-pin connector terminals at the base of steering column.
5. This test isolate the malfunction to one side of the Supplemental Restraint System (SRS) coil assembly yellow 2-pin connector located at the base of the steering column.
6. This test determines whether the malfunction is due to high resistance in the wiring.
7. This test determines whether the malfunction is in the SRS coil assembly or the driver air bag assembly.

Diagnostic Aids:

An intermittent condition is likely to be caused by a poor connection at terminals "1" and "2" of the SRS coil 2-pin connector at the base of the steering column, terminal "1" and "2" of the driver air bag assembly 2-pin connector at the top of the steering column, SDM terminals "3" and "4" or a poor wire to terminal connection in Circuit IB05-YELLOW or IB06-YELLOW/BLACK. The test for this diagnostic trouble code is only run while the "AIR BAG" warning lamp is performing the bulb check, unless Diagnostic Trouble Code (DTC) 17 or DTC 26 is detected. When a scan tool "Clear Codes" command is issued and the malfunction is still present, the DTC will not reappear until the next ignition cycle.

DTC 21 Driver Deployment Loop Resistance High

Step	Action	Yes	No
1	Was the "SRS Diagnostic System Check" performed?	Go to Step 2	Go to the "SRS Diagnostic System Check."
2	1. When measurements are requested in this chart use J-39200 DVM with correct terminal adapter from J-35616-A. 2. Use scan tool data list function, read and record the driver deployment loop resistance. Is driver deployment loop resistance more than 4.4 ohms?	Go to Step 3	Go to Chart A.
3	1. Ignition switch "OFF." 2. Disconnect driver air bag assembly yellow 2-pin connector located at base of steering column is seated properly. Is the 2-pin connector connected properly?	Go to Step 4	Seat SRS coil assembly 2-pin connector properly. Go to Step 8
4	1. Disconnect and inspect the SRS coil assembly yellow 2-pin connector located base of steering column. 2. If OK, reconnect the SRS coil assembly yellow 2-pin connector. 3. Ignition switch "ON." Is DTC 21 current?	Go to Step 5	Ignition switch "OFF." Go to Step 8
5	1. Ignition switch "OFF." 2. Disconnect SRS coil and passenger air bag assembly yellow 2-pin connectors located at the base of steering column and behind the glove box assembly. 3. Connect SRS driver / passenger load tool J-41433 and appropriate adapter to SRS coil and passenger air bag assembly harness connectors. 4. Ignition switch "ON." Is DTC 21 current?	Go to Step 6	Go to Step 7
6	1. Ignition switch "OFF." 2. There has been a increase in the total circuit resistance of the driver deployment loop. 3. Use the high resolution ohmmeter mode of the DVM while checking CKTs IB05-YEL/IB06-YEL/BLK, and SDM connector terminal "3" and "4" to locate the root cause. Was a fault found?	Replace SRS harness. Go to Step 8	Go to Chart A.
7	1. Ignition switch "OFF." Disconnect SRS driver / passenger load tool from SRS coil assembly harness connector. Connect SRS driver / passenger load tool J-41433 on the top of steering column. Reconnect SRS coil assembly harness connector as the base of steering column. Ignition switch "ON." Is DTC 21 current?	Ignition switch "OFF." Replace SRS COIL ASSEMBLY. Refer to in this section. Go to Step 8	Ignition switch "OFF." Replace driver air bag assembly. Go to Step 8
8	Reconnect all components, ensure all component are properly mounted. Clear diagnostic trouble codes. Was this step finished?	Repeat the "SRS Diagnostic System Check."	Go to Step 8.

DTC 22 Driver Deployment Loop Resistance Low

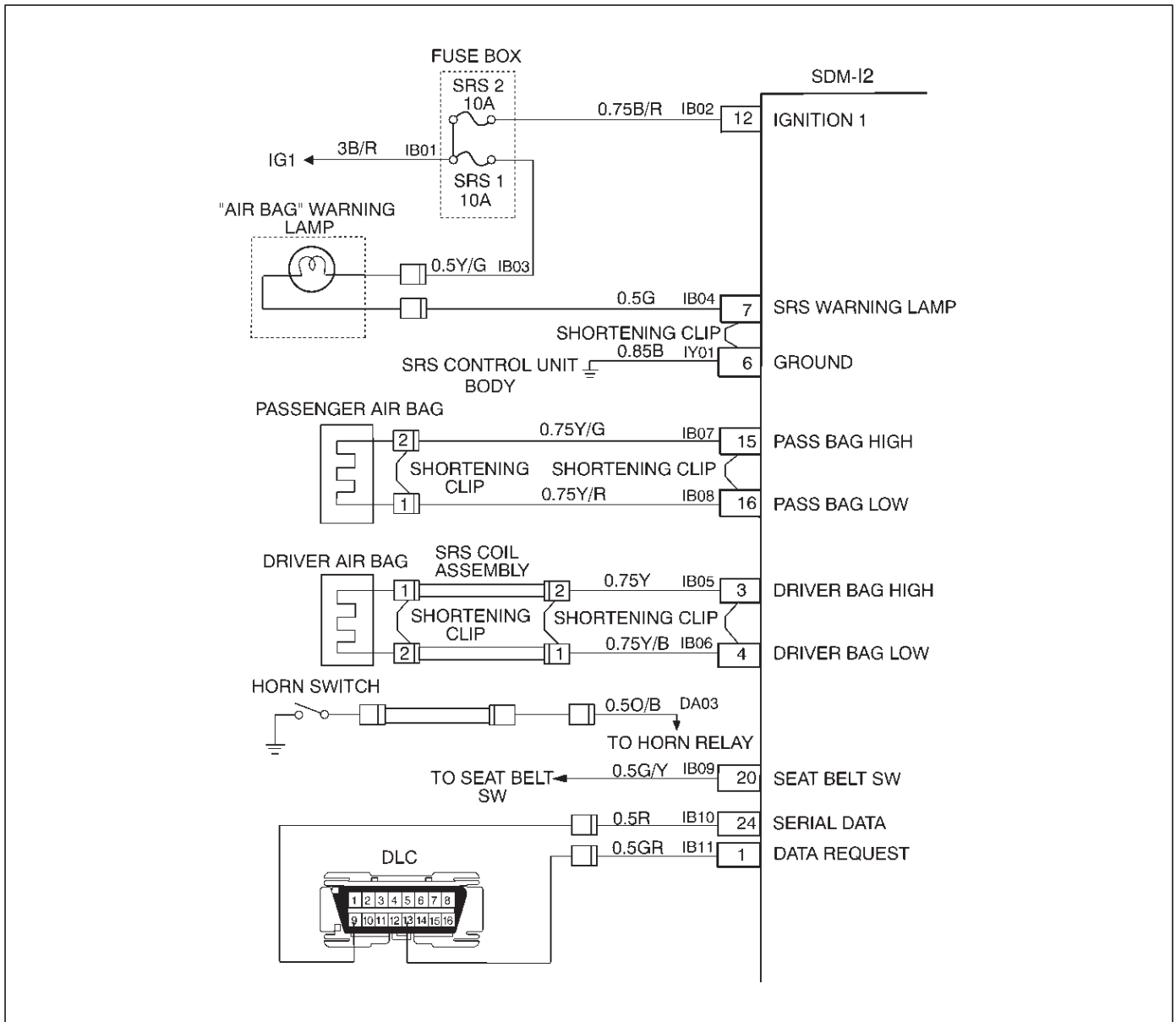

D09RX001

Circuit Description:

When the ignition switch is turned “ON”, the Sensing and Diagnostic Module (SDM) will perform tests to diagnose critical malfunctions within itself. Upon passing these tests “ignition 1”, and deployment loop voltages are measured to ensure they are within their respective normal voltage ranges. The SDM then proceeds with the “Resistance Measurement Test” “Driver Bag Low” terminal “4” is grounded through a current sink and the driver current source connected to “Driver Bag High” terminal “3” allows a known amount of current to flow. By monitoring the voltage difference between “Driver Bag High” and “Driver Bag Low” the SDM calculates the combined resistance of the driver air bag assembly, Supplemental Restraint System (SRS) coil assembly, harness wiring Circuits(CKTs) IB05–YELLOW and IB06–YELLOW/BLACK and connector terminal contact.

DTC Will Set When:

The combined resistance of the driver air bag assembly, SRS coil assembly, harness wiring CKTs IB05–YELLOW and IB06–YELLOW/BLACK and connector terminal contact is above a specified value. This test is run once each ignition cycle during the “Resistance Measurement Test” when:

- 1.No “higher priority faults” are detected during “Turn-ON”
2. “Ignition 1” voltage is in the specified value.

Action Taken:

SDM turns “ON” the “AIR BAG” warning lamp and sets DTC 22.

DTC Will Clear When:

The ignition switch is turned “OFF.”

DTC Chart Test Description:

Number(s) below refer to step number(s) on the diagnostic chart:

2. This test determines whether the malfunction is in the Sensing and Diagnostic Module (SDM).
3. This test verifies proper connection of the yellow 2-pin connector at the base of the steering column.
4. This test checks for proper operation of the shorting clip in the yellow 2-pin connector.
5. This test isolate the malfunction to one side of the Supplemental Restraint System (SRS) coil assembly yellow 2-pin connector located at the base of steering column.
6. This test determines whether the malfunction is due to shorting in the wiring.
7. This test determines whether the malfunction is in the SRS coil assembly or the driver air bag assembly.

Diagnostic Aids:

An intermittent condition is likely to be caused by a short between Circuits IB05-YELLOW or IB06-YELLOW/BLACK or a malfunctioning shorting clip on the driver air bag assembly or SRS coil assembly which would require replacement of the component. The test for this diagnostic trouble code is only run while the "AIR BAG" warning lamp is performing the bulb check, unless Diagnostic Trouble Code (DTC) 17 or DTC 26 is detected. When a scan tool "Clear Codes" command is issued and the malfunction is still present, the DTC will not reappear until the next ignition cycle.

9J1-32 RESTRAINT CONTROL SYSTEM

DTC 22 Driver Deployment Loop Resistance Low

Step	Action	Yes	No
1	Was the "SRS Diagnostic System Check" performed?	Go to Step 2	Go to the "SRS Diagnostic System Check."
2	1. When measurements are requested in this chart use J-39200 DVM with correct terminal adapter from J-35616-A. 2. Use scan tool data list function, read and record the driver deployment loop resistance. Is driver resist. less than 1.9 ohms?	Go to Step 3	Go to Chart A.
3	1. Ignition switch "OFF." 2. Make sure the SRS coil assembly yellow 2-pin connector located at the base of steering column is seated properly. Is the 2-pin connector connected properly?	Go to Step 4	Seat driver air bag assembly 2-pin connector properly. Go to Step 8
4	1. Disconnect and inspect the SRS coil assembly yellow 2-pin connector located base of steering column. 2. If OK, reconnect the driver air bag assembly yellow 2-pin connector. 3. Ignition switch "ON." Is DTC 22 current?	Go to Step 5	Ignition switch "OFF." Go to Step 8
5	1. Ignition switch "OFF." 2. Disconnect SRS coil and passenger air bag 2-pin connectors located at the base of steering column and behind the glove box assembly. 3. Connect SRS driver / passenger load tool J-41433 and appropriate adapter to SRS coil and passenger air bag assembly harness connectors. 4. Ignition switch "ON." Is DTC 22 current?	Go to Step 6	Go to Step 7
6	1. Ignition switch "OFF." 2. There has been a decrease in the total circuit resistance of the driver deployment loop. 3. Use the high resolution ohmmeter mode of the DVM while checking CKTs IB05-YEL and IB06-YEL/BLK, and SDM connector terminal "3" and "4" to locate the root cause. Was a fault found?	Replace SRS harness. Go to Step 8	Go to Chart A.
7	1. Ignition switch "OFF." 2. Disconnect SRS driver / passenger load tool from SRS coil assembly harness connector. 3. Connect SRS driver / passenger load tool J-41433 to the top of steering column. 4. Reconnect SRS coil assembly harness connector as the base of steering column. 5. Ignition switch "ON." Is DTC 22 current?	Ignition switch "OFF." Replace SRS coil assembly. Refer to in this section. Go to Step 8	Ignition switch "OFF." Replace driver air bag assembly. Go to Step 8
8	1. Reconnect all components, ensure all component are properly mounted. 2. Clear diagnostic trouble codes. Was this step finished?	Repeat the "SRS Diagnostic System Check."	Go to Step 8

DTC 24 Driver Deployment Loop Short To Ground

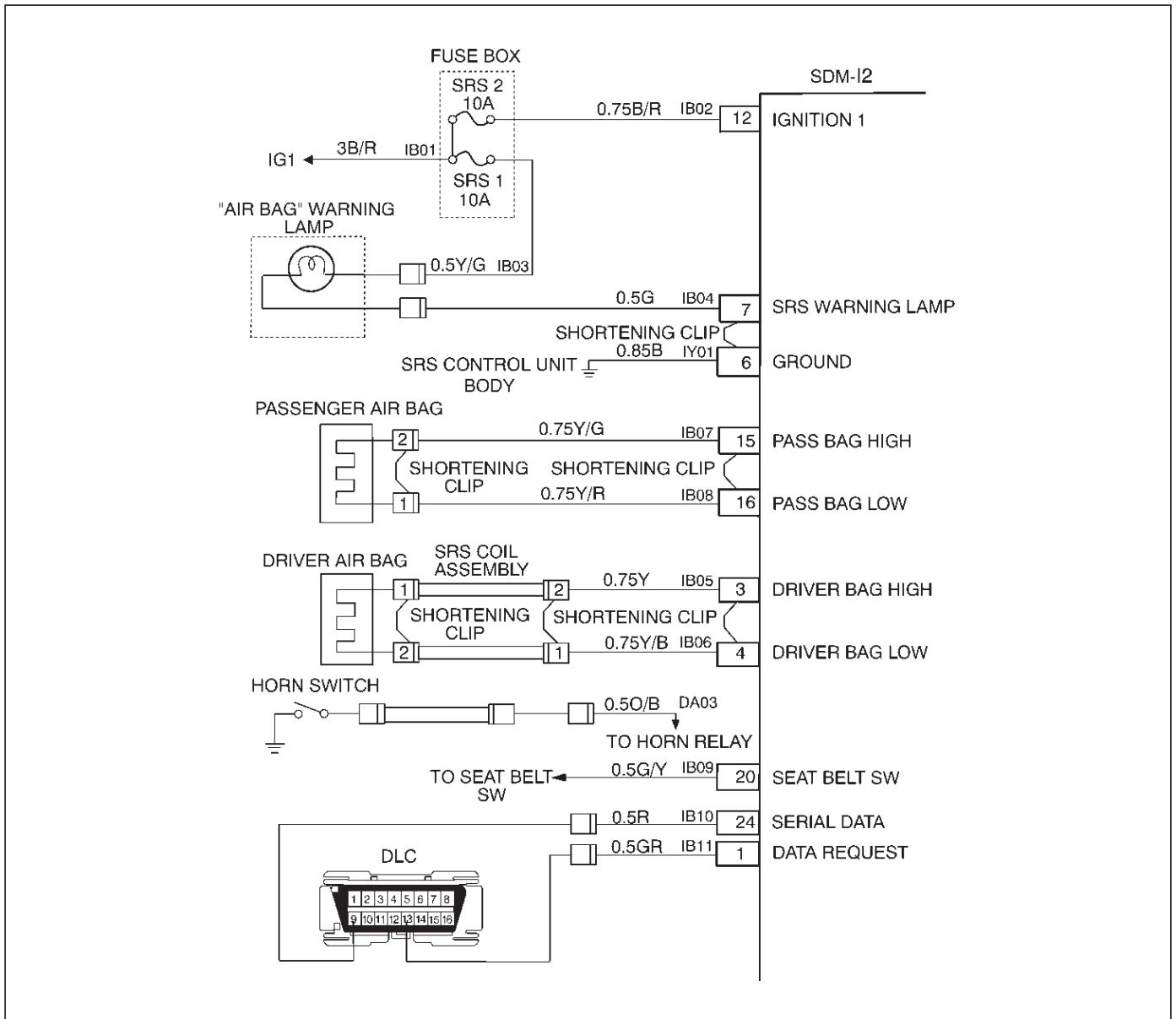

D09RX001

Circuit Description:

When the ignition switch is turned "ON", the Sensing and Diagnostic Module (SDM) will perform tests to diagnose critical malfunctions within itself. Upon passing these tests, "ignition 1", and deployment loop voltages are measured to ensure they are within their respective normal voltage ranges.

The SDM monitors the voltage at "Driver Bag Low" terminal "4" and "Passenger Bag Low" terminal "16" to detect shorts to ground in the air bag assembly circuits.

DTC Will Set When:

Neither of the two air bag assemblies is open. "Ignition 1" is within the normal operating voltage range. This test is run once each ignition cycle and "Continuous Monitoring". Once these conditions are met and the voltage at "Driver Bag Low" is below a specified value, DTC 24 will set.

Action Taken:

SDM turns "ON" the "AIR BAG" warning lamp and sets a diagnostic trouble code.

DTC Will Clear When:

The malfunction is no longer occurring and the ignition is turned "OFF."

DTC Chart Test Description:

Number(s) below refer to step number(s) on the diagnostic chart:

2. This test determines whether the SDM is malfunctioning
3. This test isolates the malfunction to one side of the Supplemental Restraint System (SRS) coil assembly yellow 2-pin connector at the base of the steering column.
4. This test determines whether the malfunction is in Circuit(CKT) IB05-YELLOW.

9J1-34 RESTRAINT CONTROL SYSTEM

5. This test determines whether the malfunction is in CKT IB06-YELLOW/BLACK.
6. This test determines whether the malfunction is in the SRS coil assembly or the driver air bag assembly.

Diagnostic Aids:

An intermittent condition is likely to be caused by a short to ground in the driver air bag assembly circuit. Inspect CKTs IB05-YELLOW and IB06-YELLOW/BLACK carefully for cutting or chafing.

DTC 24 Driver Deployment Loop Short To Ground

Step	Action	Yes	No
1	Was the "SRS Diagnostic System Check" performed?	Go to Step 2	Go to the "SRS Diagnostic System Check."
2	<ol style="list-style-type: none"> When measurements are requested in this chart use J-39200 DVM with correct terminal adapter from J-35616-A. Ignition switch "OFF." Connect scan tool data link connector. Follow directions as given in the scan tool operator's manual. Ignition switch "ON." Read driver sense LO. Is driver sense LO less than 1.5 volts?	Go to Step 3	Go to Chart A.
3	<ol style="list-style-type: none"> Ignition switch "OFF." Disconnect SRS coil assembly yellow 2-pin connector located at base of the steering column. Leave passenger air bag assembly connected. Connect SRS driver / passenger load tool J-41433 and appropriate adapter to SRS coil assembly harness connector. Ignition switch "ON." Is DTC 24 current?	Go to Step 4	Go to Step 6
4	<ol style="list-style-type: none"> Ignition switch "OFF." Disconnect SDM. Disconnect SRS driver / passenger load tool. Measure resistance on SDM harness connector "3" to terminal "6" (ground). Does J-39200 display "0L" (infinite)?	Go to Step 5	Replace SRS harness. Go to Step 7
5	Measure resistance on SDM harness connector from terminal "4" to terminal "6" (ground). Does J-39200 display "0L" (infinite)?	Go to Chart A.	Replace SRS harness. Go to Step 7
6	<ol style="list-style-type: none"> Ignition switch "OFF." Disconnect SRS driver / passenger load tool J-41433 from SRS coil assembly harness connector. Connect SRS driver / passenger load tool J-41433 and appropriate adapter J-35616-A to driver air bag assembly harness connector. Located top of the steering column. Reconnect SRS coil assembly harness connector as the base of steering column. Ignition switch "ON." Is DTC 24 current?	Ignition switch "OFF." Replace SRS coil assembly. Refer to in this section. Go to Step 7	Ignition switch "OFF." Replace driver air bag assembly. Go to Step 7
7	<ol style="list-style-type: none"> Reconnect all components, ensure all component are properly mounted. Clear diagnostic trouble codes. Was this step finished?	Repeat the "SRS Diagnostic System Check."	Go to Step 7

DTC 25 Driver Deployment Loop Short To Voltage

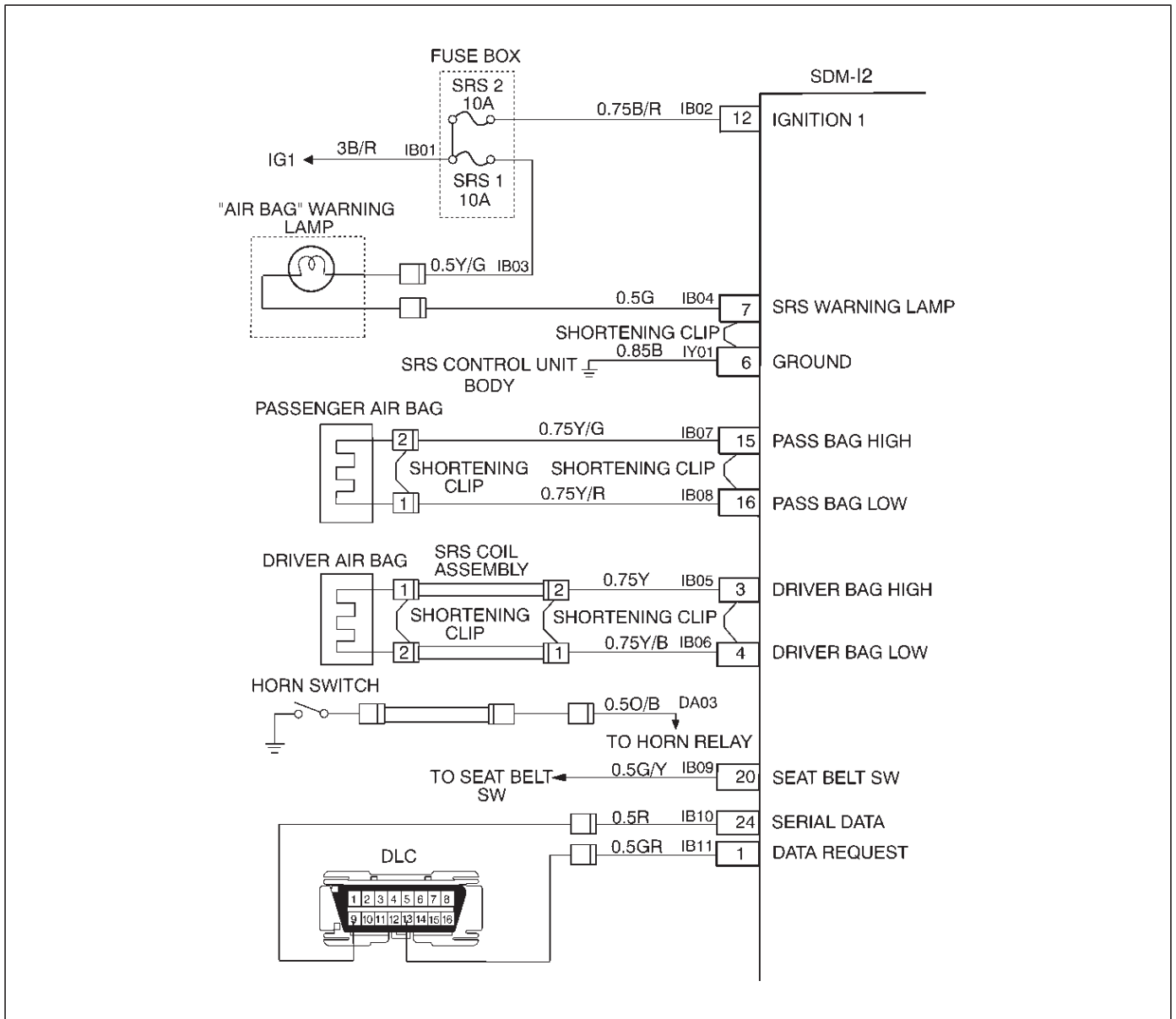

D09RX001

Circuit Description:

When the ignition switch is turned "ON", the Sensing and Diagnostic Module (SDM) will perform tests to diagnose critical malfunctions within itself. Upon passing these tests, "ignition 1", and deployment loop voltages are measured to ensure they are within their respective normal voltage ranges.

The SDM monitors the voltage at "Driver Bag Low" terminal "4" and "Passenger Bag Low" terminal "16" to detect shorts to B+ in the air bag assembly circuits.

DTC Will Set When:

"Ignition 1" is in the normal operating voltage range. This test is run once each ignition cycle and "Continuous Monitoring". Once these conditions are met and the voltage at "Driver Bag Low" is above a specified value, Diagnostic Trouble Code (DTC) 25 will set.

Action Taken:

SDM turns "ON" the "AIR BAG" warning lamp and sets DTC 25 and also DTC 71

DTC Will Clear When:

The SDM is replaced.

DTC Chart Test Description:

Number(s) below refer to step number(s) on the diagnostic chart:

2. This test determines whether the SDM is malfunctioning.
3. This test isolates the malfunction to one side of the Supplemental Restraint System coil assembly yellow 2-pin connector at the base of steering column.
4. This test determines whether the malfunction is in Circuit(CKT) IB05-YELLOW.

9J1-36 RESTRAINT CONTROL SYSTEM

5. This test determines whether the malfunction is in CKT IB06-YELLOW/BLACK.
6. This test determines whether the malfunction is in the Supplemental Restraint System (SRS) coil assembly or the driver air bag assembly.

Diagnostic Aids:

An intermittent condition is likely to be caused by a short to B+ in the driver air bag assembly circuit. Inspect CKTs IB05-YELLOW and IB06-YELLOW/BLACK carefully for cutting or chafing. If the wiring pigtail of the driver air bag assembly and SRS coil assembly is damaged, the components must be replaced. A careful inspection of CKT IB05-YELLOW and IB06-YELLOW/BLACK, including the SRS coil assembly and driver air bag assembly is essential to ensure that the replacement Sensing and Diagnostic Module (SDM) will not be damaged.

DTC 25 Driver Deployment Loop Short To Ignition

CAUTION: When Diagnostic Trouble Code (DTC) 25 has been set, it is necessary to replace the Sensing and Diagnostic Module (SDM). Setting DTC 25 will also cause DTC 71 to set. When a scan tool “CLEAR CODES” command is issued and the malfunction is no longer present, DTC 71 will remain current. Ensure that the short to voltage condition is repaired prior to installing a replacement SDM to avoid damaging the SDM.

Step	Action	Yes	No
1	Was the “SRS Diagnostic System Check” performed?	Go to Step 2	Go to the “SRS Diagnostic System Check.”
2	<ol style="list-style-type: none"> When measurements are requested in this chart use J-39200 DVM with correct terminal adapter from J-35616-A. Ignition switch “OFF.” Connect scan tool data link connector. Follow directions as given in the scan tool operator’s manual. Ignition switch “ON.” Read driver sense LO. Is driver sense LO more than 3.5 volts?	Go to Step 3	Go to Chart A.
3	<ol style="list-style-type: none"> Ignition switch “OFF.” Disconnect SRS coil assembly yellow 2-pin connector at the base of the steering column. Leave passenger air bag assembly connected. Connect SRS driver / passenger load tool J-41433 and appropriate adapter to SRS coil assembly harness connector. Ignition switch “ON.” Is driver sense LO more than 3.5 volts?	Go to Step 4	Go to Step 6
4	<ol style="list-style-type: none"> Ignition switch “OFF.” Disconnect SDM. Disconnect SRS driver / passenger load tool. Measure resistance on SDM harness connector from terminal “3” to terminal “12” (Ignition 1). Does J-39200 display “0L” (infinite)?	Go to Step 5	Replace SRS harness. Go to Step 7
5	Measure resistance on SDM harness connector from terminal “4” to terminal “12” (Ignition 1). Does J-39200 display “0L” (infinite)?	Go to Chart A.	Replace SRS harness. Go to Step 7
6	<ol style="list-style-type: none"> Ignition switch “OFF.” Connect SRS driver / passenger load tool J-41433 and appropriate adapter J-35616-A to driver air bag assembly harness connector located of top of the steering column. Reconnect SRS coil assembly harness connector as the base of steering column. Ignition switch “ON.” Is driver sense LO more than 3.5 volts?	Ignition switch “OFF.” Replace SRS coil assembly. Go to Step 7	Ignition switch “OFF.” Replace driver air bag assembly. Go to Step 7
7	<ol style="list-style-type: none"> Reconnect all components, ensure all components are properly mounted. Ignition switch “ON.” Is passenger sense LO less than 3.5 volts?	Replace SDM. Go to Step 8	Go to Chart A.
8	<ol style="list-style-type: none"> Reconnect all components, ensure all components are properly mounted. Clear diagnostic trouble codes. Was this step finished?	Repeat the “SRS Diagnostic System Check.”	Go to Step 8

DTC 26 Driver Deployment Loop Open

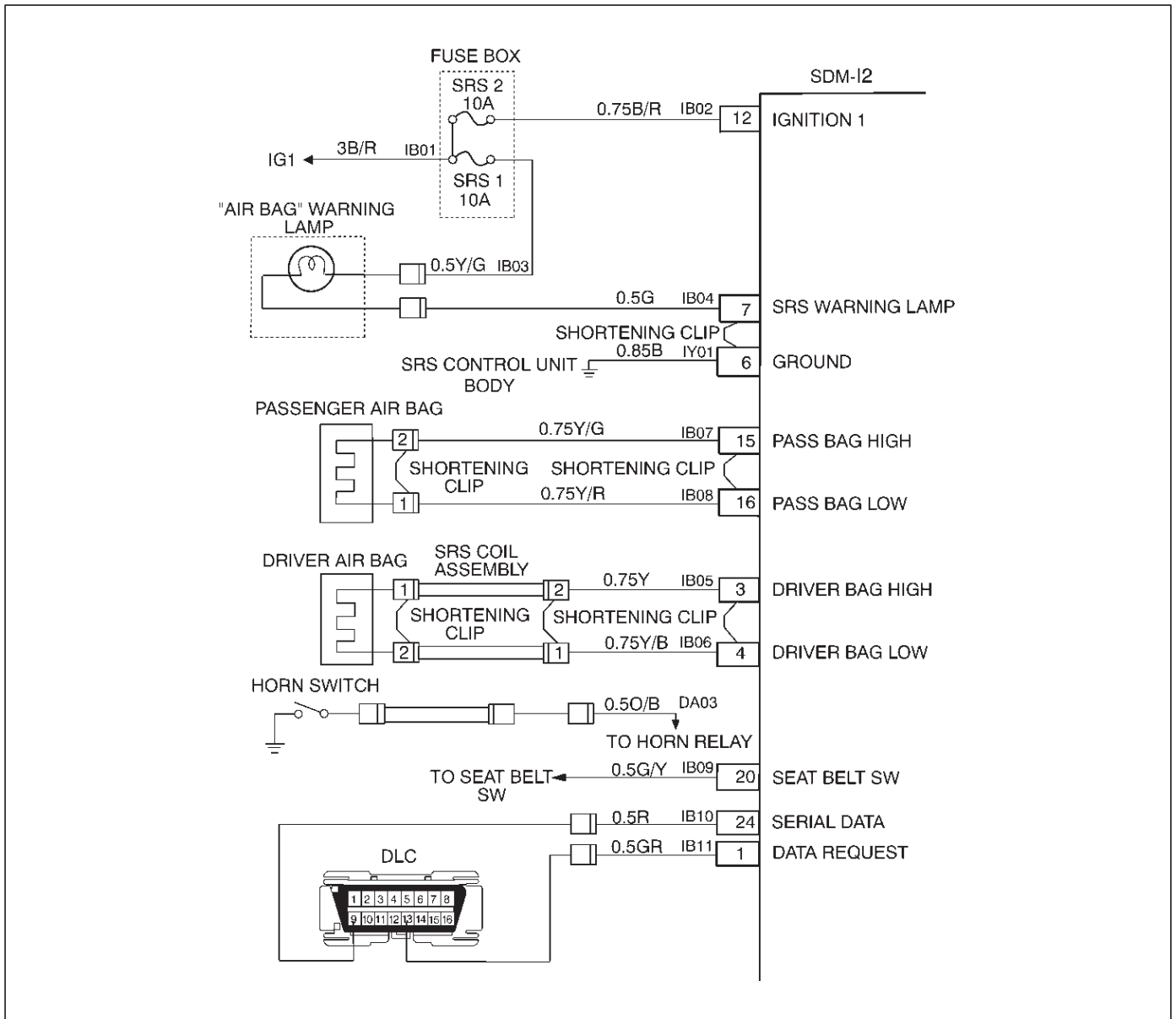

Circuit Description:

When the ignition switch is turned “ON”, the Sensing and Diagnostic Module (SDM) will perform tests to diagnose critical malfunctions within itself. Upon passing these tests, “ignition 1”, and deployment loop voltages are measured to ensure they are within their respective normal voltage ranges.

During “Continuous Monitoring” diagnostics, a fixed amount of current is following in the deployment loop. This produces proportional voltage drops in the loop. By monitoring the voltage difference between “Driver Bag High” and “Driver Bag Low”, the SDM calculates the combined resistance of the driver air bag assembly, SRS coil assembly, harness wiring Circuits (CKTs) IB05–YELLOW and IB06–YELLOW/BLACK, and connector terminal contact.

DTC Will Set When:

The voltage difference between “Driver Bag High” terminal “3” and “Driver Bag Low” terminal “4” is above or equal to a specified value for 500 milliseconds during “Continuous Monitoring.”

Action Taken:

SDM turns “ON” the “AIR BAG” warning lamp and sets a diagnostic trouble code.

DTC Will Clear When:

The voltage difference between “Driver Bag High” terminal “3” and “Driver Bag Low” terminal “4” is below a specified value for 500 milliseconds during “Continuous Monitoring.”

DTC Chart Test Description:

Number(s) below refer to circled number(s) on the diagnostic chart:

1. This test determines whether the malfunction is in the Sensing and Diagnostic Module (SDM).
2. This test verifies proper connection of the yellow 2-pin connector at the base of the steering column.
3. This test checks for proper contact and/or corrosion of the yellow 2-pin connector at the base of the steering column.
4. This test isolates the malfunction to one side of the Supplemental Restraint System (SRS) coil assembly yellow 2-pin connector located at the base of steering column.
5. This test determines whether the open is in the wiring.
6. This test determines whether the malfunction is in the SRS coil assembly or the driver air bag assembly.

Diagnostic Aids:

An intermittent condition is likely to be caused by a poor connection at the driver air bag assembly harness 2-pin connector terminals "1" and "2" at the top of the steering column, SRS coil assembly harness 2-pin connection terminals "1" and "2", SDM terminals "3" and "4", or an open in Circuits(CKTs) IB05-YELLOW and IB06-YELLOW/BLACK.

9J1-40 RESTRAINT CONTROL SYSTEM

DTC 26 Driver Deployment Loop Open

Step	Action	Yes	No
1	Was the "SRS Diagnostic System Check" performed?	Go to Step 2	Go to the "SRS Diagnostic System Check."
2	1. When measurements are requested in this chart use J-39200 DVM with correct terminal adapter from J-35616-A. 2. Use scan tool data list function, read and record the driver differential voltage. Is driver differential voltage more than 4.25 volts?	Go to Step 3	Go to Chart A.
3	1. Ignition switch "OFF." 2. Make sure the SRS coil assembly yellow 2-pin connector located at the base of steering column is seated properly. Is the yellow 2-pin connector connected properly?	Go to Step 4	Seat driver air bag assembly 2-pin connector. Go to Step 8
4	1. Disconnect and inspect the SRS coil assembly yellow 2-pin connector located base of steering column. 2. If OK, reconnect the SRS coil assembly yellow 2-pin connector. 3. Ignition switch "ON". Is DTC 26 current?	Go to Step 5	Ignition switch "OFF." Go to Step 8
5	1. Ignition switch "OFF." 2. Disconnect SRS coil and passenger air bag assembly, yellow 2-pin connectors located at the base of steering column and behind the glove box assembly. 3. Connect SRS driver / passenger load tool J-41433 and appropriate adapter to SRS coil and passenger air bag assembly harness connectors. 4. Ignition switch "ON." Is DTC 26 current?	Go to Step 6	Go to Step 7
6	1. Ignition switch "OFF." 2. There has been an open circuit in the driver deployment loop. Use the high resolution ohmmeter mode of the DVM while checking CKTs IB05 YEL and IB06 YEL/BLK, and SDM connector terminal "3" AND "4" to locate the root cause. Was a fault found?	Replace SRS harness. Go to Step 8	Go to Chart A.
7	1. Ignition switch "OFF." 2. Disconnect SRS driver / passenger load tool from SRS coil assembly harness connector. 3. Connect SRS driver / passenger load tool J-41433 on steering column. 4. Reconnect SRS coil assembly harness connector as the base of steering column. 5. Ignition switch "ON." Is DTC 26 current?	Ignition switch "OFF." Replace SRS coil assembly, refer to in this section. Go to Step 8	Ignition switch "OFF." Replace driver air bag assembly. Go to Step 8
8	1. Reconnect all components, ensure all component are properly mounted. 2. Clear diagnostic trouble codes. Was this step finished?	Repeat the "SRS Diagnostic System Check."	Go to Step 8

DTC 51 Deployment Event Commanded

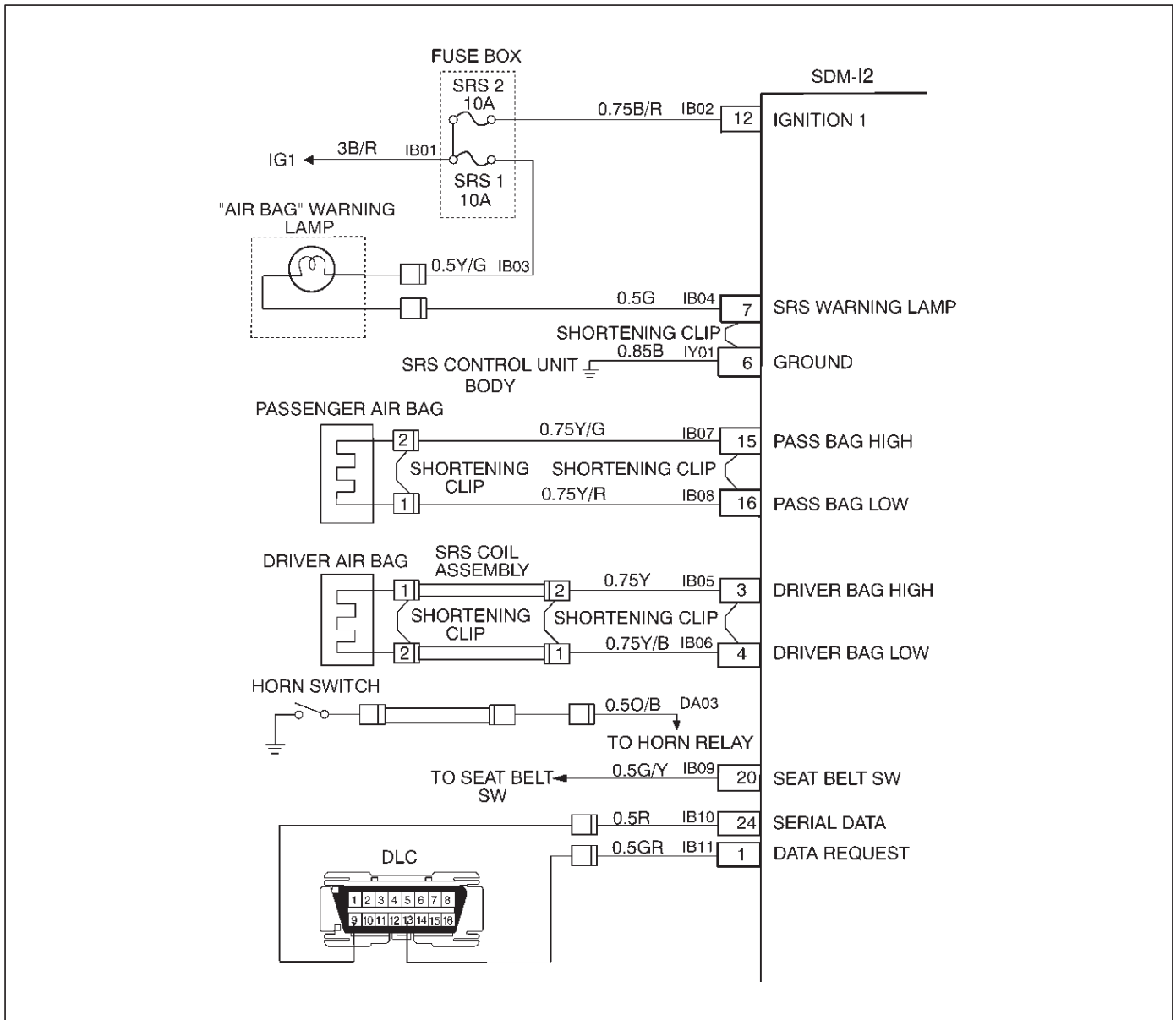

D09RX001

Circuit Description:

The Sensing and Diagnostic Module (SDM) contains a sensing device which converts vehicle velocity changes to an electrical signal. The electrical signal generated is processed by the SDM and then compared to a value stored in memory. When the generated signal exceeds the stored value, the SDM will cause current to flow through the air bag assembly deploying the air bags and causing Diagnostic Trouble Code (DTC) 51 to set.

DTC Will Set When:

The SDM detects a frontal crash, up to 30 degrees off the centerline of the vehicle, of sufficient force to warrant deployment of the air bags.

Action Taken:

SDM turns "ON" the "AIR BAG" warning lamp records "Crash Data", and sets a diagnostic trouble code.

DTC Will Clear When:

The SDM is replaced.

DTC Chart Test Description:

Number(s) below refer to step number(s) on the diagnostic chart:

2. If air bag assembly (s) has not deployed, DTC 51 may have falsely set.
3. If DTC 51 has set with no signs of frontal impact, the diagnostic trouble code has falsely set.

DTC 51 Deployment Event Commanded

WARNING: DURING SERVICE PROCEDURES. BE VERY CAREFUL WHEN HANDLING A SENSING AND DIAGNOSTIC MODULE (SDM). NEVER STRIKE OR JAR THE SDM. NEVER POWER UP THE SRS WHEN THE SDM IS NOT RIGIDLY ATTACHED TO THE VEHICLE. ALL SDM AND MOUNTING BRACKET FASTENERS MUST BE CAREFULLY TORQUED AND THE ARROW MUST BE POINTING TOWARD THE FRONT OF THE VEHICLE TO ENSURE PROPER OPERATION OF THE SUPPLEMENTAL RESTRAINT SYSTEM (SRS). THE SDM COULD BE ACTIVATED WHEN POWERED WHILE NOT RIGIDLY ATTACHED TO THE VEHICLE WHICH COULD CAUSE DEPLOYMENT AND RESULT IN PERSONAL INJURY.

Step	Action	Yes	No
1	Was the "SRS Diagnostic System Check" performed?	Go to Step 2	Go to the "SRS Diagnostic System Check."
2	Ignition switch "OFF." Have air bag assemblies deployed?	Replace components and perform inspections as directed in "repairs and inspections required after an accident" in this section. Clear diagnostic trouble codes. Repeat the "SRS Diagnostic System Check."	Go to Step 3
3	Inspect front of vehicle and undercarriage for signs of impact. Were signs of impact found?	Replace components and perform inspections as directed in "repairs and inspections required after an accident" in this section. Clear diagnostic trouble codes. Repeat the "SRS Diagnostic System Check."	Ignition switch "OFF." Replace SDM. Reconnect all SRS system components, ensure all components are properly mounted.Repeat the "SRS Diagnostic System Check."

DTC 53 Deployment Commanded With Deployment Loop Fault Or Energy Reserves Out Of Range

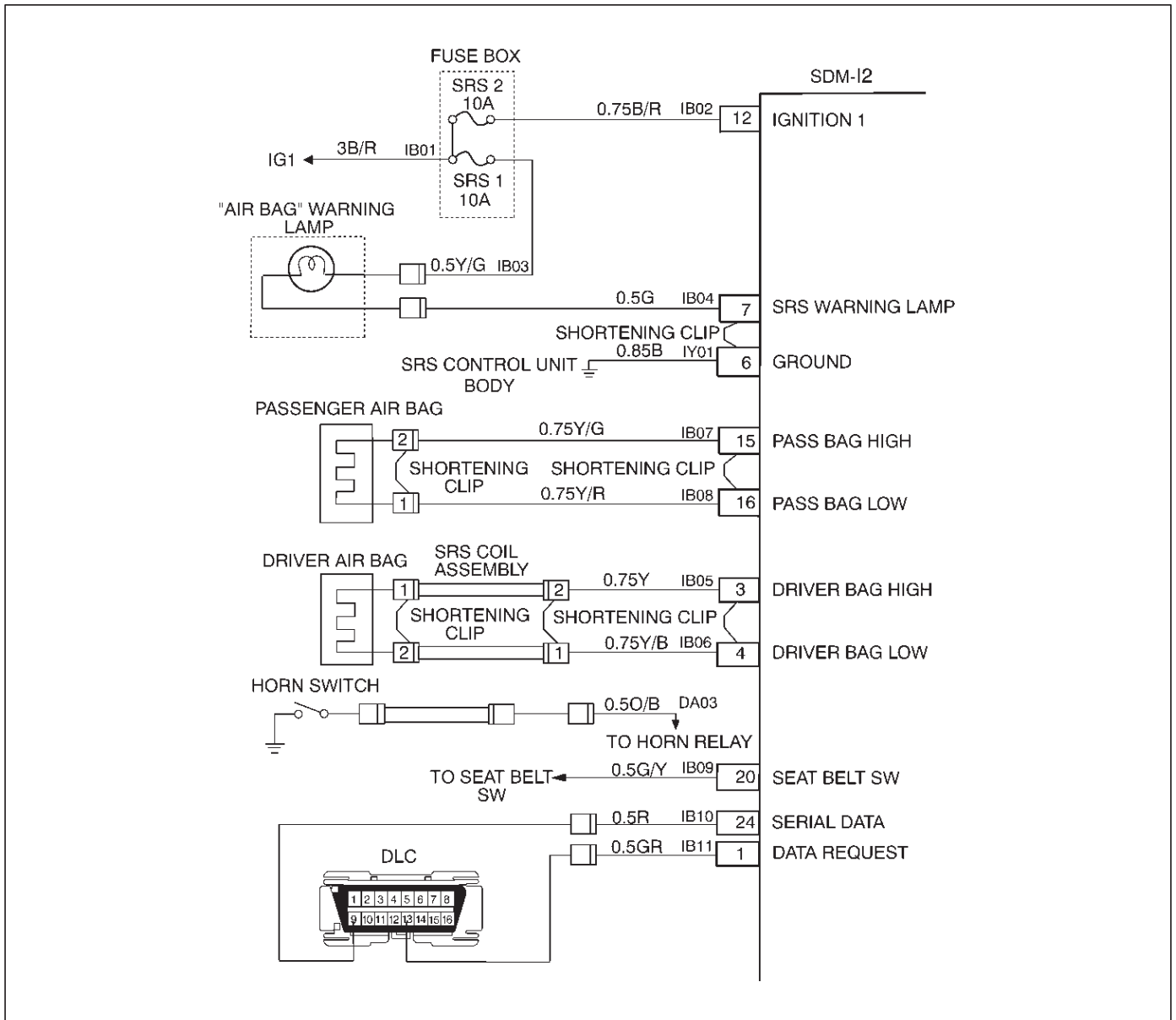

D09RX001

Circuit Description:

The Sensing and Diagnostic Module (SDM) contains a sensing drive which converts vehicle velocity changes to an electrical signal. The electrical signal generated is processed by the SDM and then compared to a value stored in memory. When the generated signal exceeds the stored value, the SDM will cause current to flow through the air bag assembly deploying the air bags. Diagnostic Trouble Code (DTC) 53 is set accompanying with DTC 51 when a deployment occurs while an air bag assembly circuit fault is present that could possibly result in a no deployment situation in one or both air bag assemblies.

DTC Will Set When:

The SDM detects a frontal crash, up to 30 degrees off the centerline of the vehicle, of sufficient force to warrant

deployment of the air bags and an inflator circuit fault is present.

Action Taken:

SDM turns "ON" the "AIR BAG" warning lamp records "Crash Data", and sets a diagnostic trouble code.

DTC Will Clear When:

The SDM is replaced. If DTC 53 is set, one or more DTCs will be set in addition to DTC 53. Malfunction(s) setting DTC(s) (other than DTC 71) must be repaired so that DTC(s) will not be set when a new SDM is installed.

DTC Chart Test Description:

Number(s) below refer to step number(s) on the diagnostic chart:

2. If air bag assembly has not deployed, Diagnostic Trouble Code (DTC) 53 may have falsely set.

9J1-44 RESTRAINT CONTROL SYSTEM

3. If DTC 53 has set with no signs of frontal impact, the diagnostic trouble code has falsely set.

DTC 53 Deployment Commanded With Deployment Loop Fault Or Energy Reserves Out Of Range

WARNING: DURING SERVICE PROCEDURES. BE VERY CAREFUL WHEN HANDLING A SENSING AND DIAGNOSTIC MODULE (SDM). NEVER STRIKE OR JAR THE SDM. NEVER POWER UP THE SRS WHEN THE SDM IS NOT RIGIDLY ATTACHED TO THE VEHICLE. ALL SDM AND MOUNTING BRACKET FASTENERS MUST BE CAREFULLY TORQUED AND THE ARROW MUST BE POINTING TOWARD THE FRONT OF THE VEHICLE TO ENSURE PROPER OPERATION OF THE SRS. THE SDM COULD BE ACTIVATED WHEN POWERED WHILE NOT RIGIDLY ATTACHED TO THE VEHICLE WHICH COULD CAUSE DEPLOYMENT AND RESULT IN PERSONAL INJURY.

Step	Action	Yes	No
1	Was the "SRS Diagnostic System Check" performed?	Go to Step 2	Go to the "SRS Diagnostic System Check."
2	Ignition switch "OFF." Have air bag assemblies deployed?	Replace components and perform inspections as directed in "repairs and inspections required after an accident" in this section. Clear diagnostic trouble codes. Repeat the "SRS Diagnostic System Check."	Go to Step 3
3	Inspect front of vehicle and undercarriage for signs of impact. Were signs of impact found?	Replace components and perform inspections as directed in "repairs and inspections required after an accident" in this section. Clear diagnostic trouble codes. Repeat the "SRS Diagnostic System Check."	Ignition switch "OFF." Replace SDM. Reconnect all SRS system components, ensure all components are properly mounted. Repeat the "SRS Diagnostic System Check."

DTC 61 Warning Lamp Circuit Failure

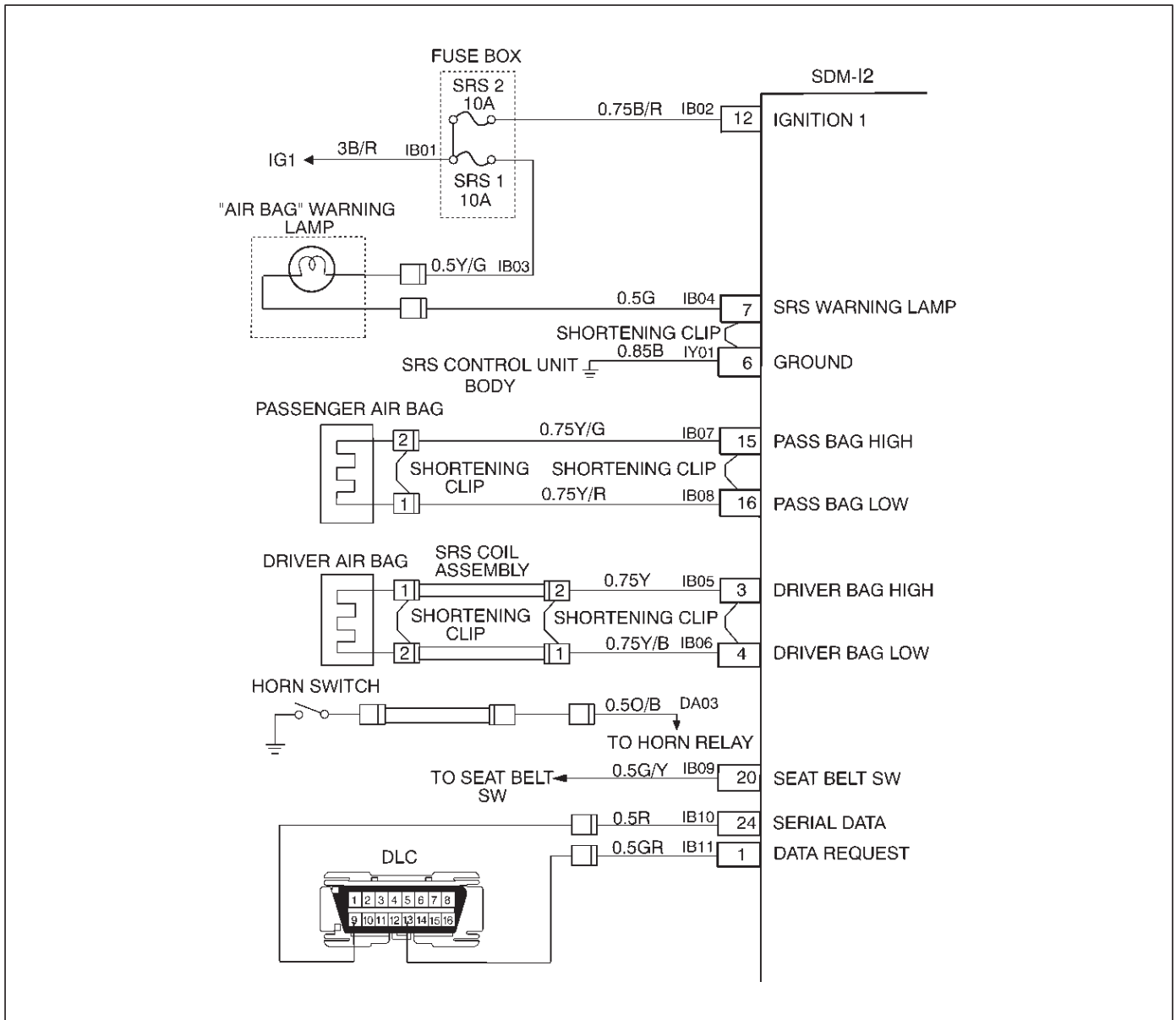

D09RX001

Circuit Description:

When the ignition switch is turned "ON", battery voltage is applied to the "AIR BAG" warning lamp and to the "ignition 1" input terminal "12". The Sensing and Diagnostic Module (SDM) responds by flashing the "AIR BAG" warning lamp seven times. The SDM monitors the lamp driver output by comparing the output state at "Supplemental Restraint System (SRS) warning lamp" terminal "7" to the microprocessor commanded state. When "ignition 1" is in the specified value, and the output state Does not match the commanded state of the lamp driver for 500 milliseconds, DTC 61 is set.

DTC Will Set When:

"Ignition 1" voltage is in the specified value and the output state at the "SRS warning lamp" terminal does not match

the commanded state of the lamp driver for 500 milliseconds. This test is run every 100 milliseconds during "Continuous Monitoring" tests and once per each ignition cycle at the beginning.

Action Taken:

SDM attempts to turn "ON" the "AIR BAG" warning lamp and sets a diagnostic trouble code.

DTC Will Clear When:

The ignition switch is turned "OFF."

Diagnostic Aids:

Refer to Charts B and C to diagnose warning lamp circuit malfunctions.

DTC 61 Warning Lamp Circuit Failure

Step	Action	Yes	No
1	Was the "SRS Diagnostic System Check" performed?	Go to Step 2	Go to the "SRS Diagnostic System Check."
2	1. Malfunctions within the "AIR BAG" warning lamp circuitry will set this diagnostic trouble code. 2. These malfunctions are addressed in the "SRS Diagnostic System Check" via Chart B and Chart C. 3. Failure to properly perform the "SRS Diagnostic System Check" may result in misdiagnosis. 4. Ignition switch "ON." 5. Clear SRS diagnostic trouble codes. Is DTC 61 SET?	Ignition switch "OFF." Go to Chart A.	Repeat the "SRS Diagnostic System Check."

DTC 71 Internal SDM Fault

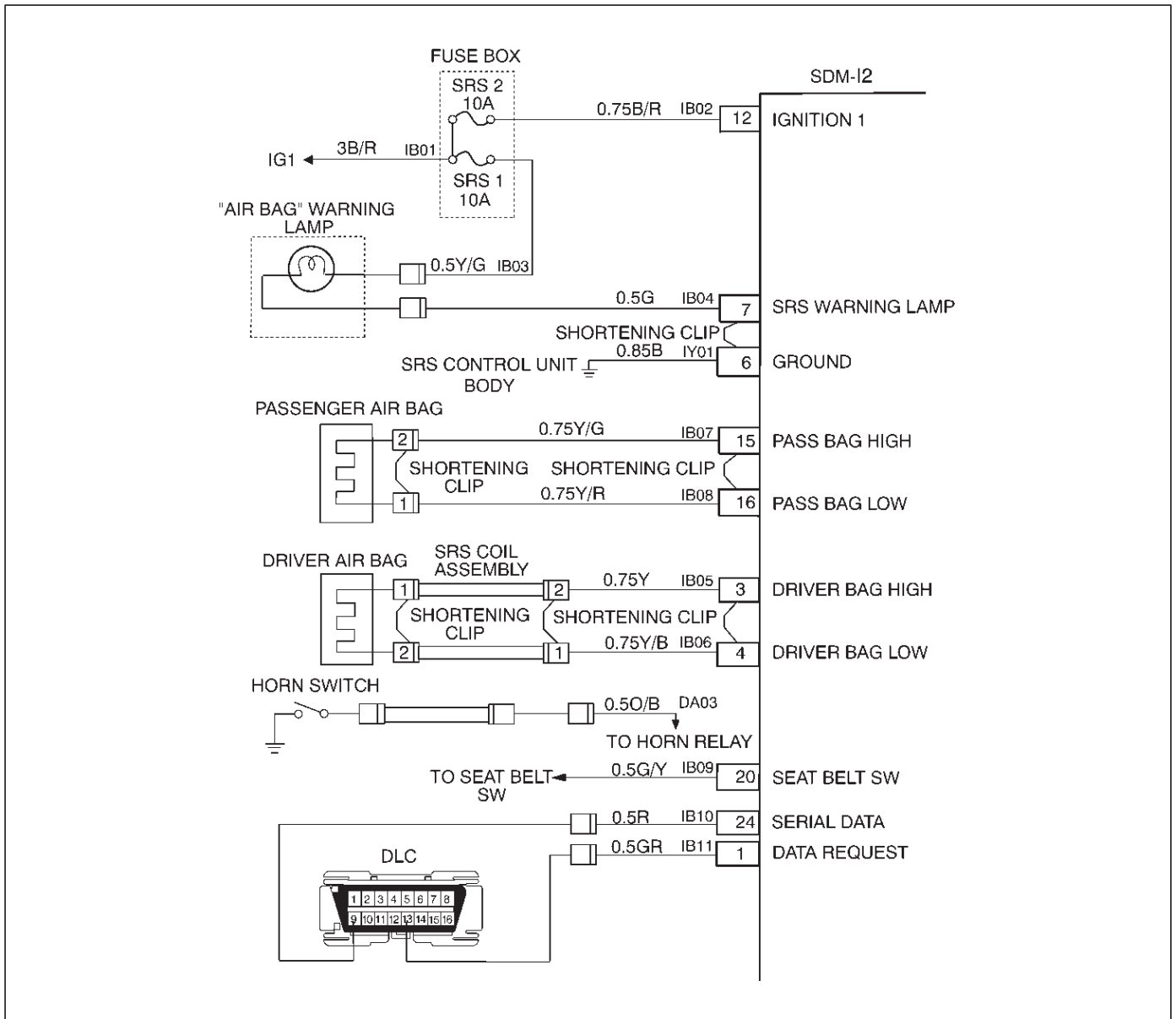

D09RX001

Circuit Description:

Diagnostic Trouble Code (DTC) 71 is an indication of a potential internal Sensing and Diagnostic Module (SDM) malfunction and will set if any of the following conditions are detected:

- 1) Deployment or microprocessor energy reserve failure.
- 2) Electronically Erasable Programmable Read Only Memory failure. (EEPROM).
- 3) Random Only Memory failure. (ROM).
- 4) Random Access Memory failure. (RAM).
- 5) Calibration check sum failure.
- 6) Deployment switch faults.
- 7) Accelerometer fault.
- 8) Arming sensor fault.
- 9) Diagnostic current faults.
- 10) DTC 19
- 11) DTC 25
- 12) DTC 51

13) DTC 53

DTC Will Set When:

Any of the above indicated malfunctions are detected by the SDM. The malfunctions described above are tested mainly during "Continuous Monitoring" and some ones run each ignition cycle.

Action Taken:

SDM turns "ON" the "AIR BAG" warning lamp and sets a diagnostic trouble code.

DTC Will Clear When:

A scan tool "Clear Codes" commanded is received by the SDM. Some of the indicated malfunctions will only allow the "AIR BAG" warning lamp to go out. But when DTC 19, 25, 51, 53 are also set, SDM is Replaced.

DTC 71 Internal SDM Fault

WARNING: DURING SERVICE PROCEDURES. BE VERY CAREFUL WHEN HANDLING A SENSING AND DIAGNOSTIC MODULE (SDM). NEVER STRIKE OR JAR THE SDM. NEVER POWER UP THE SRS WHEN THE SDM IS NOT RIGIDLY ATTACHED TO THE VEHICLE. ALL SDM AND MOUNTING BRACKET FASTENERS MUST BE CAREFULLY TORQUED AND THE ARROW MUST BE POINTING TOWARD THE FRONT OF THE VEHICLE TO ENSURE PROPER OPERATION OF THE SRS. THE SDM COULD BE ACTIVATED WHEN POWERED WHILE NOT RIGIDLY ATTACHED TO THE VEHICLE WHICH COULD CAUSE DEPLOYMENT AND RESULT IN PERSONAL INJURY.

CAUTION: When Diagnostic Trouble Code (DTC) 19 or 25 or 51 or 53 has been set it is necessary to Replace the SDM. Setting DTC 19 and 25 or 51 or 53 will also cause DTC 71 to set. When a scan tool "CLEAR CODES" command is issued and the malfunction is no longer present, DTC 51 or 53 and DTC 71 will remain current. Ensure that the short to voltage condition DTC 19, 25 is repaired prior to installing a Replacement SDM to avoid damaging the SDM.

Step	Action	Yes	No
1	Was the "SRS Diagnostic System Check" performed?	Go to Step 2	Go to the "SRS Diagnostic System Check."
2	Note SRS "Diagnostic System Check." Is DTC 19 or 25 or 51 or 53 also set (current or history)? (Refer to notice above).	Go to DTC 19 if DTC 19 is set. Go to DTC 25 if DTC 25 is set. Go to DTC 51 if DTC 51 is set. Go to DTC 53 if DTC 53 is set.	Ignition switch "OFF." Replace SDM. Repeat the "SRS Diagnostic System Check."